

Worldwide Pollution Control Association

WPCA-
Southern Company
Mercury Seminar
October 30-31, 2012

All presentations posted on this website are copyrighted by the Worldwide Pollution Control Association (WPCA). Any unauthorized downloading, attempts to modify or to incorporate into other presentations, link to other websites, or to obtain copies for any other purposes than the training of attendees to WPCA Conferences is expressly prohibited, unless approved in writing by the WPCA or the original presenter. The WPCA does not assume any liability for the accuracy or contents of any materials contained in this library which were presented and/or created by persons who were not employees of the WPCA.



Visit our website at www.wpca.info





Mercury Measurement: Technology Choices, Accuracy and Repeatability

Jim Wright
Peter Kaufmann
Clean Air Engineering

October 31, 2012

Focus of this talk

- Sorbent trap monitoring for mercury
- Performance Specification 12B
- MATS

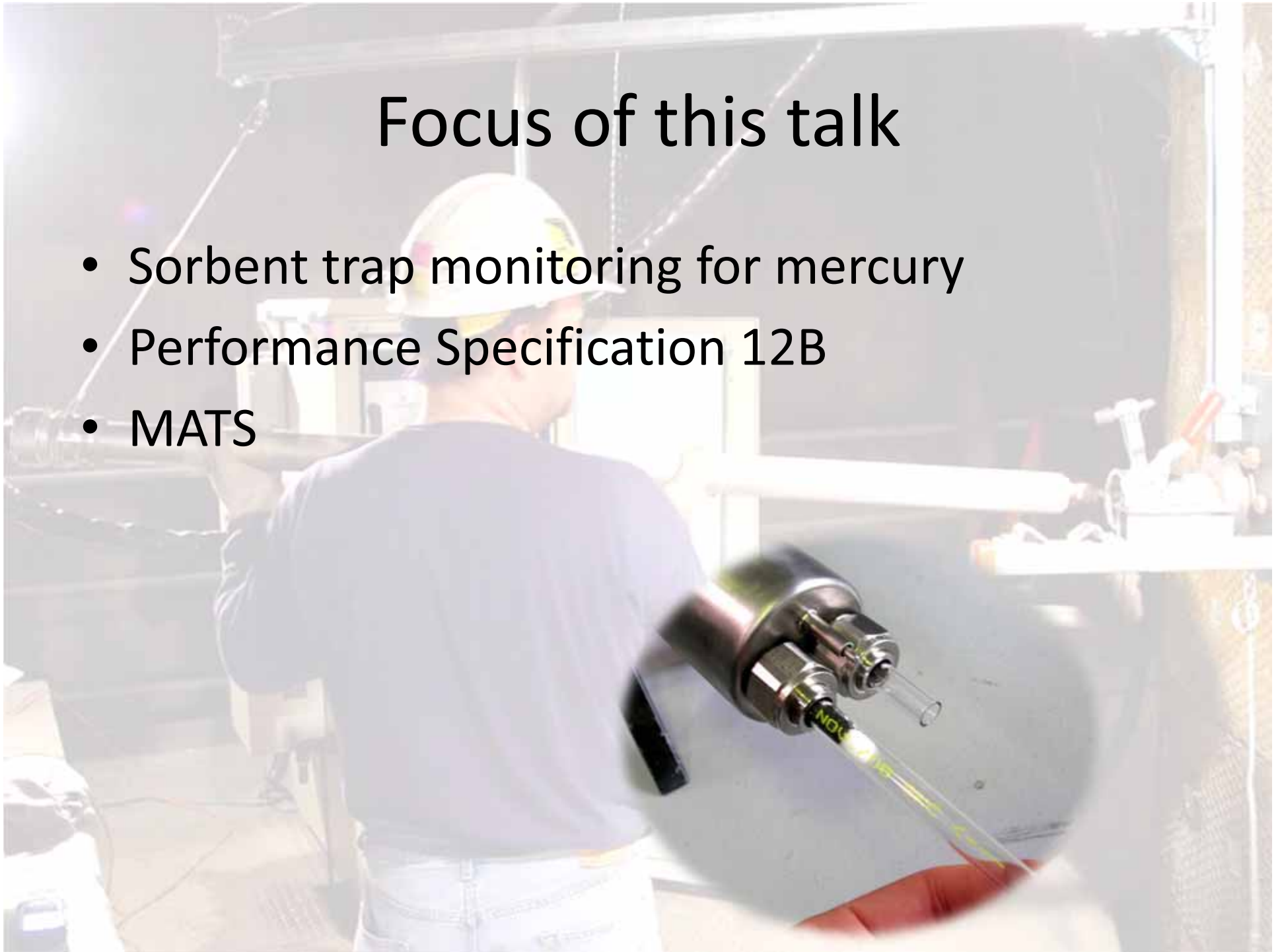

Overview

- Relevance
- Approach
- Data



Measuring Mercury

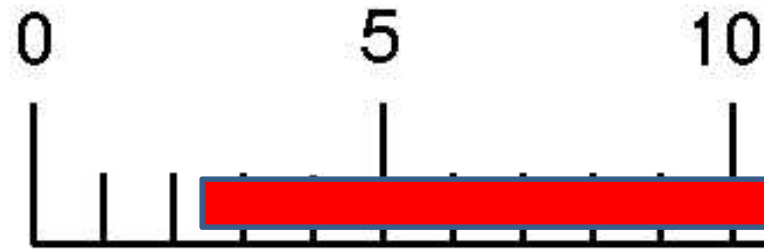

- EPA Method 101 (101A)
- EPA Method 29
- ASTM Method D6784 (Ontario Hydro)

Measuring Mercury

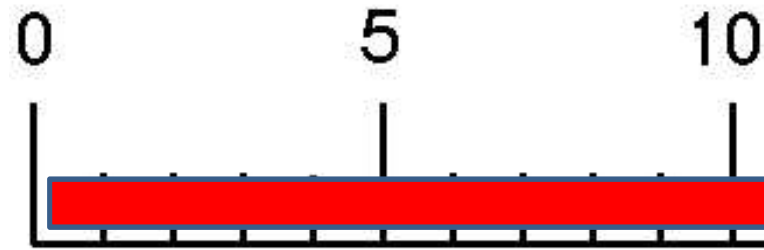

- EPA Method 30B

Measuring Mercury

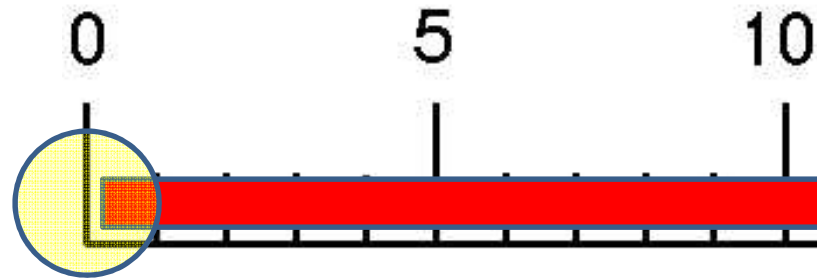

- EPA Method 30B
- Performance Specification 12A (Hg CEMS)
- Performance Specification 12B (STMMS)

The status of Hg CEMS

Getting better all the time...

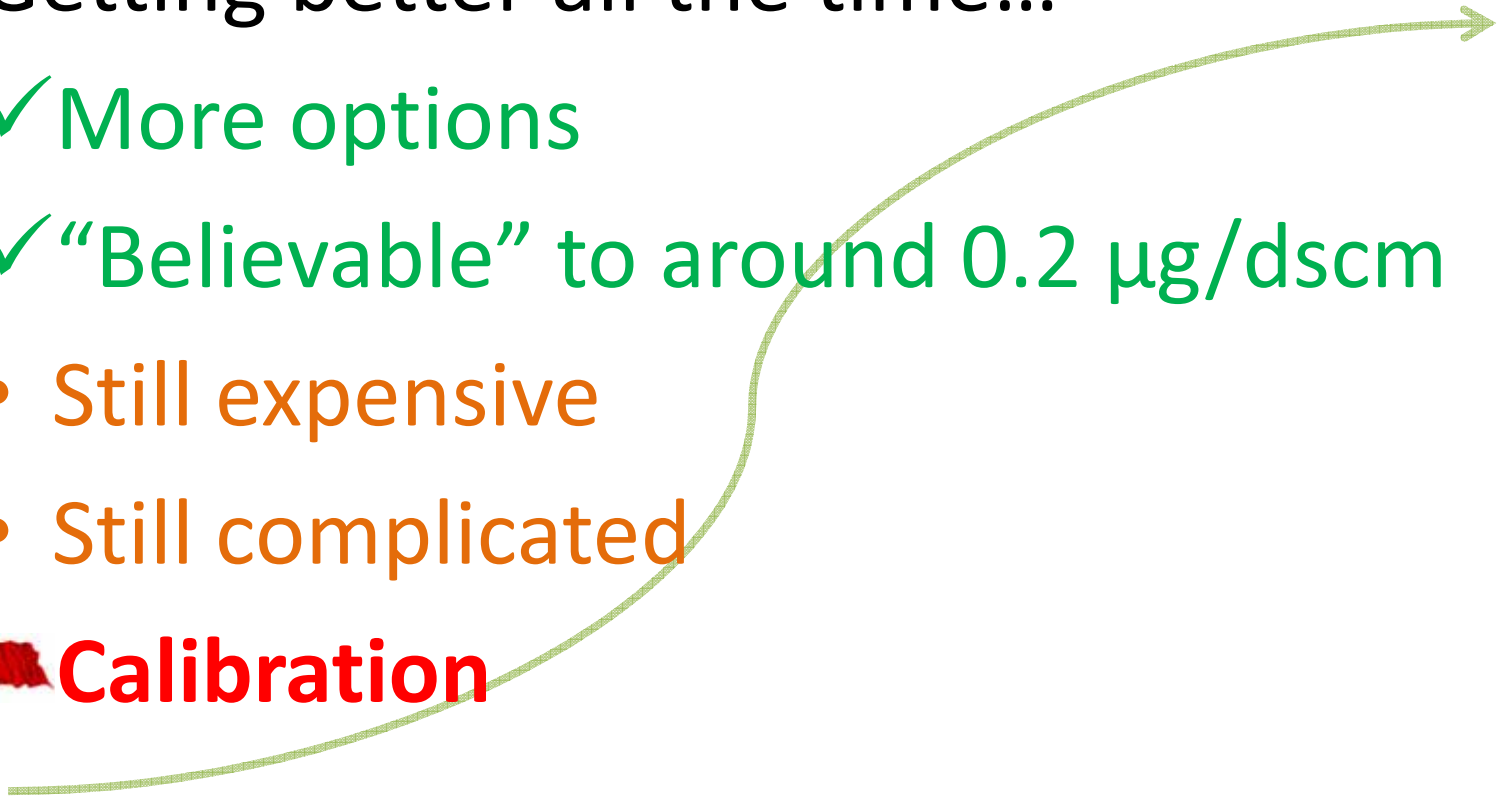
- ✓ More options
 - ✓ “Believable” to around $0.2 \mu\text{g/dscm}$
 - Still expensive
 - Still complicated
 - 🚩 **Calibration**
- 

MATS Limits

TABLE 3—EMISSION LIMITATIONS FOR COAL-FIRED AND SOLID OIL-DERIVED FUEL-FIRED EGUS

Subcategory	Filterable particulate matter	Hydrogen chloride	Mercury
Existing—Unit not low rank virgin coal	3.0E-2 lb/MMBtu. (3.0E-1 lb/MWh)	2.0E-3 lb/MMBtu. (2.0E-2 lb/MWh)	1.2E0 lb/TBtu. (1.3E-2 lb/GWh).
Existing—Unit designed low rank virgin coal	3.0E-2 lb/MMBtu. (3.0E-1 lb/MWh)	2.0E-3 lb/MMBtu. (2.0E-2 lb/MWh)	1.1E+1 lb/TBtu. (1.2E-1 lb/GWh). 4.0E0 lb/TBtu ^a . (4.0E-2 lb/GWh ^a).
Existing—IGCC	4.0E-2 lb/MMBtu. (4.0E-1 lb/MWh)	5.0E-4 lb/MMBtu. (5.0E-3 lb/MWh)	2.5E0 lb/TBtu. (3.0E-2 lb/GWh).
Existing—Solid oil-derived	8.0E-3 lb/MMBtu. (9.0E-2 lb/MWh)	5.0E-3 lb/MMBtu. (8.0E-2 lb/MWh)	2.0E-1 lb/TBtu. (2.0E-3 lb/GWh).
New—Unit not low rank virgin coal	7.0E-3 lb/MWh	4.0E-4 lb/MWh	2.0E-4 lb/GWh.
New—Unit designed for low rank virgin coal	7.0E-3 lb/MWh	4.0E-4 lb/MWh	4.0E-2 lb/GWh.
New—IGCC	7.0E-2 lb/MWh ^b 9.0E-2 lb/MWh ^c	2.0E-3 lb/MWh ^d	3.0E-3 lb/GWh ^e .
New—Solid oil-derived	2.0E-2 lb/MWh	4.0E-4 lb/MWh	2.0E-3 lb/GWh.

Note: lb/MMBtu = pounds pollutant per million British thermal units fuel input.

lb/TBtu = pounds pollutant per trillion British thermal units fuel input.

lb/MWh = pounds pollutant per megawatt-hour electric output (gross).

lb/GWh = pounds pollutant per gigawatt-hour electric output (gross).

^a Beyond-the-floor limit as discussed elsewhere.

^b Duct burners on syngas; based on permit levels in comments received.

0.024 µg/dscm

NIST Calibrators



Source: EPRI CEMS, 2012, Thermo Supergroup

NIST Calibrators

- Today
0-10 $\mu\text{g}/\text{dscm}$
low point of 2.7

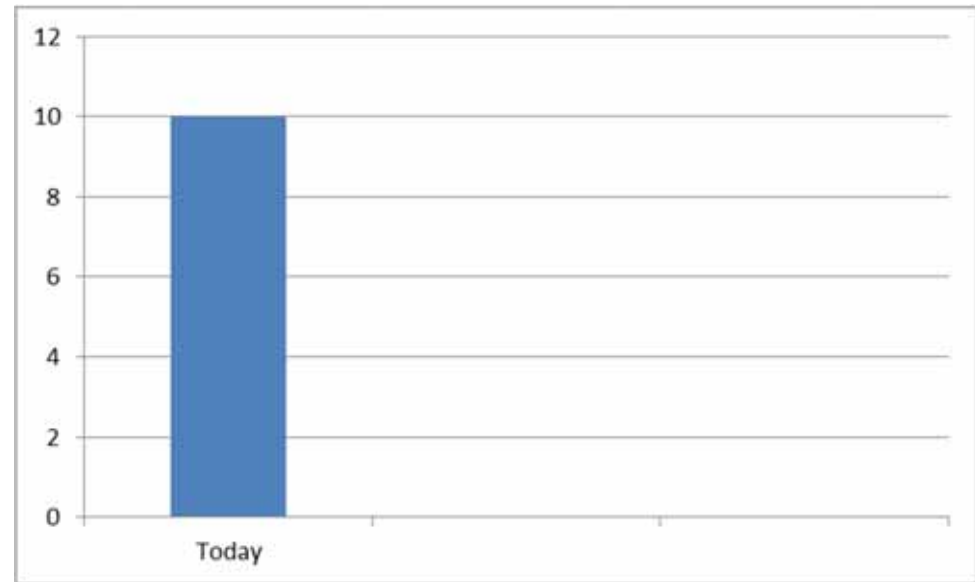

Source: EPRI CEMS, 2012, Thermo Supergroup

NIST Calibrators

- Today
0-10 $\mu\text{g}/\text{dscm}$
low point of 2.7
- Someday
0-1 $\mu\text{g}/\text{dscm}$
low point of 0.2

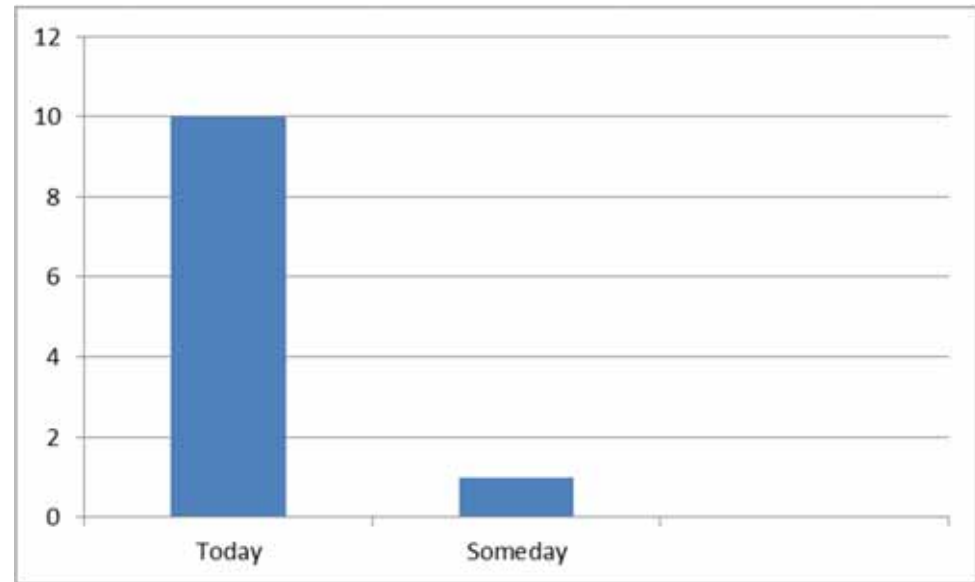

Source: EPRI CEMS, 2012, Thermo Supergroup

NIST Calibrators

- Today
0-10 $\mu\text{g}/\text{dscm}$
low point of 2.7
- Someday
0-1 $\mu\text{g}/\text{dscm}$
low point of 0.2
- MATS Limit = 0.024

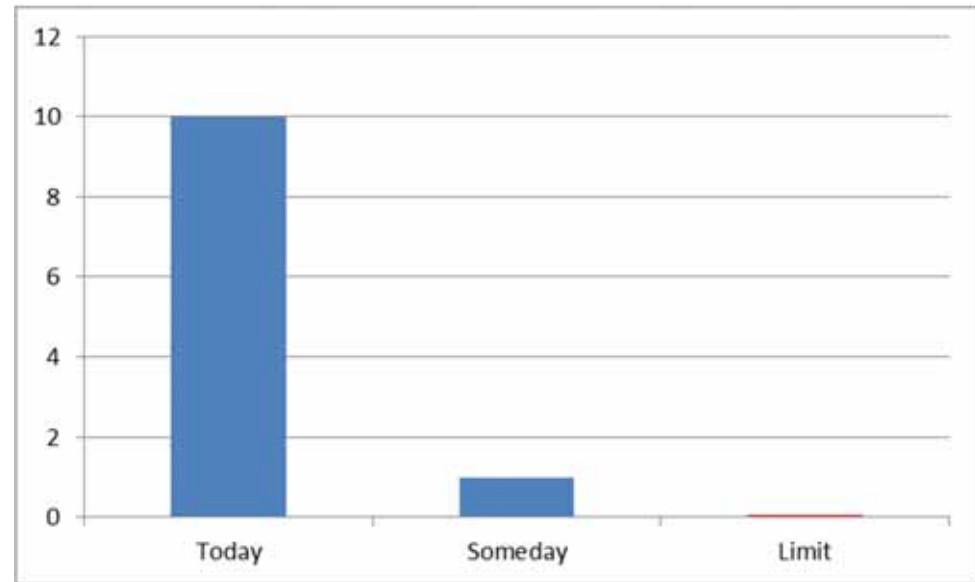

Source: EPRI CEMS, 2012, Thermo Supergroup

Two new units

- Permitted at 0.1 $\mu\text{g}/\text{dscm}$
- Sorbent trap monitoring
- Two primary and two back-up systems

0.0035 $\mu\text{g}/\text{dscm}$

What are sorbent traps used for?

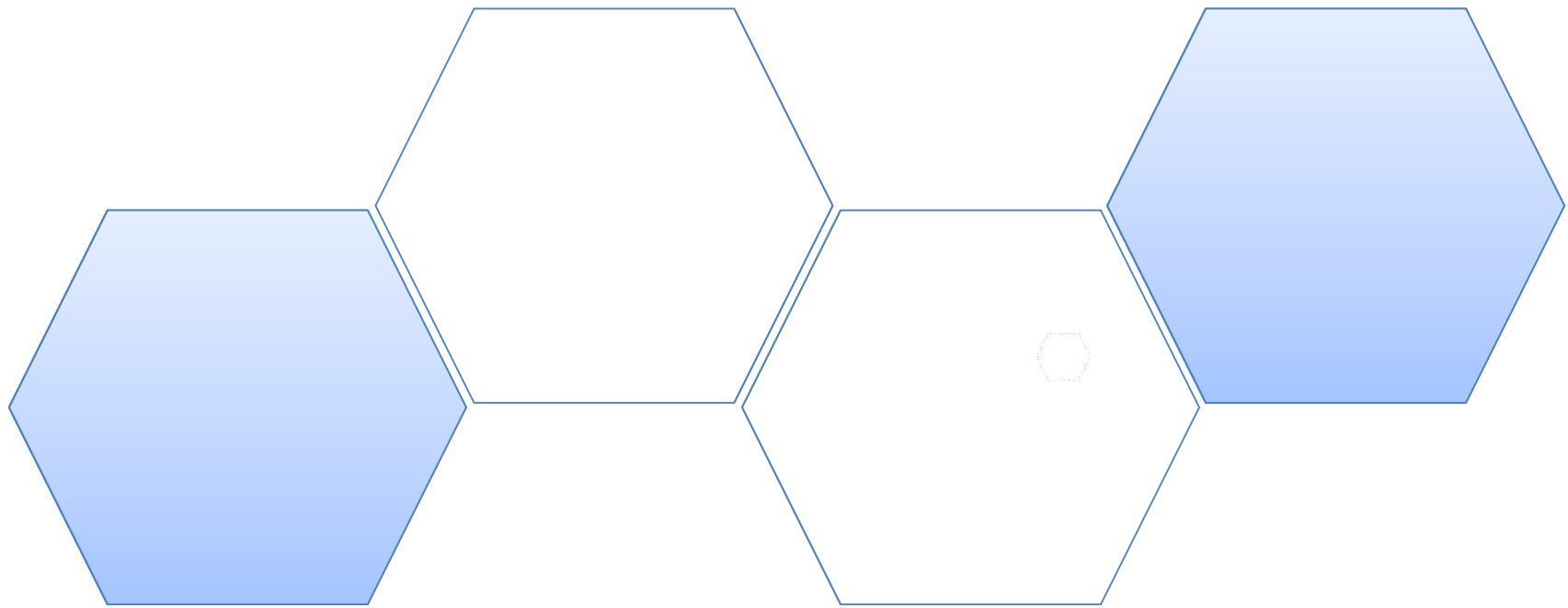

What are sorbent traps used for?



What are sorbent traps used for?



Testing



RATA

MATS Planning

LEE Evaluation

Control Equipment
Evaluation

Permit Compliance

EPA Method 30B

Monitoring



Hg CEMS
Back-up

Performance
Specification
12B

Hg CEMS
Alternative



- Simplicity
- NIST-traceable
- It works
- Cost-effective

WHY?



Method 30B
VS
Ontario Hydro Method

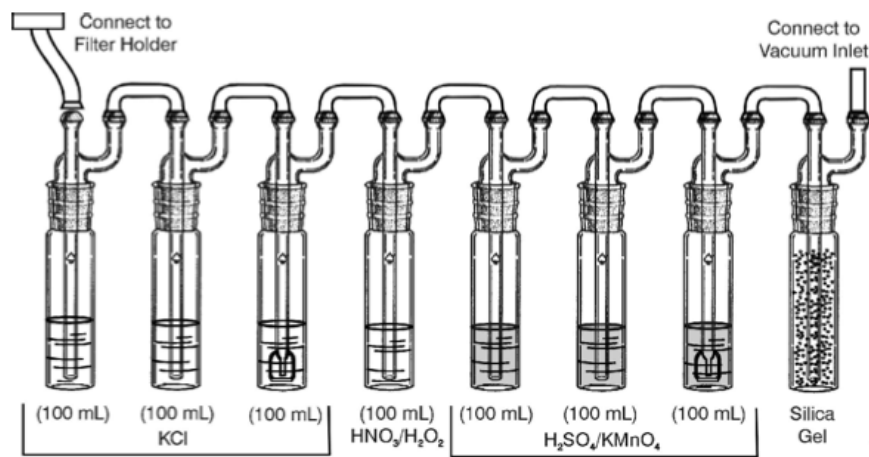



STMMS
vs
Hg CEMS



Simplicity

No hazardous chemicals



Simplicity

Simple to ship traps



Simplicity

Simple mechanical equipment

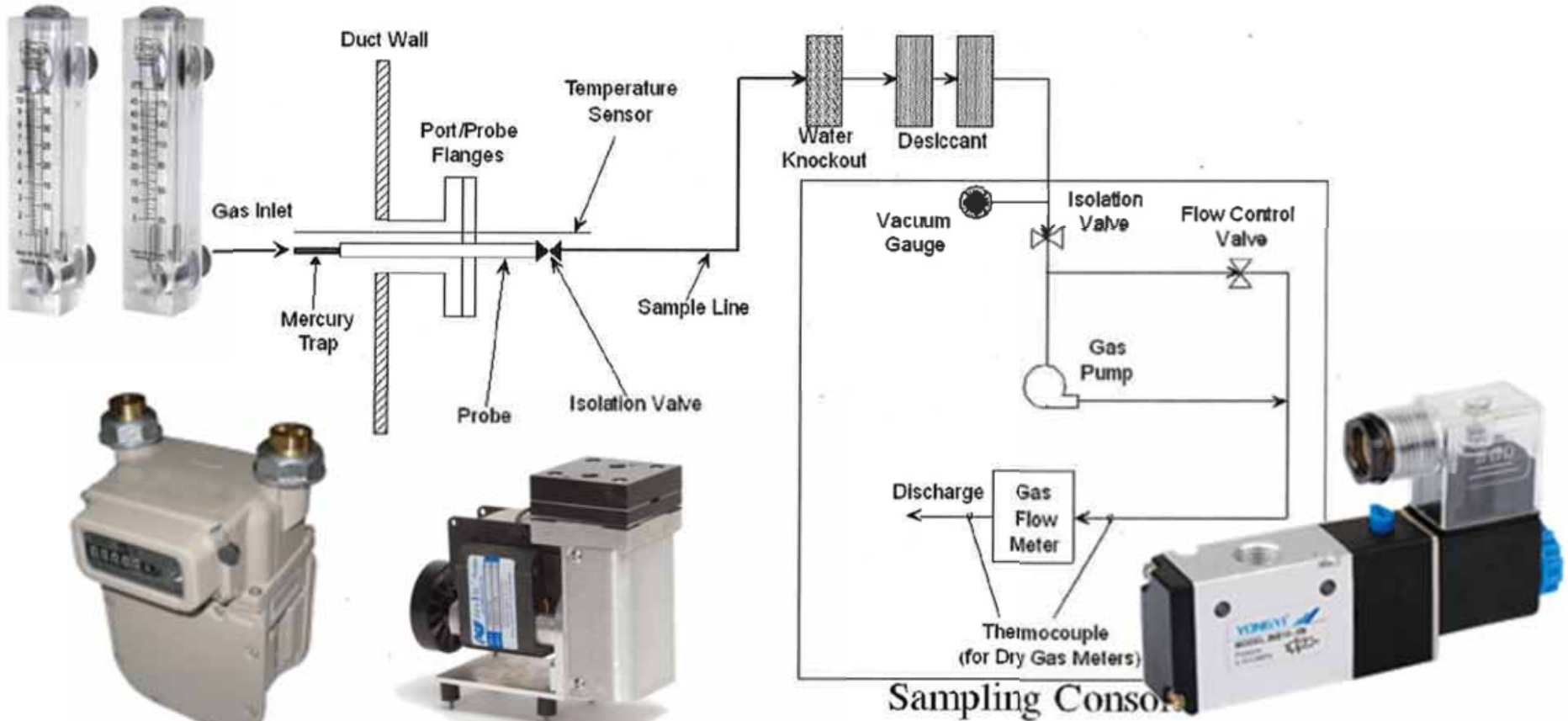

Simplicity

Simple mechanical equipment

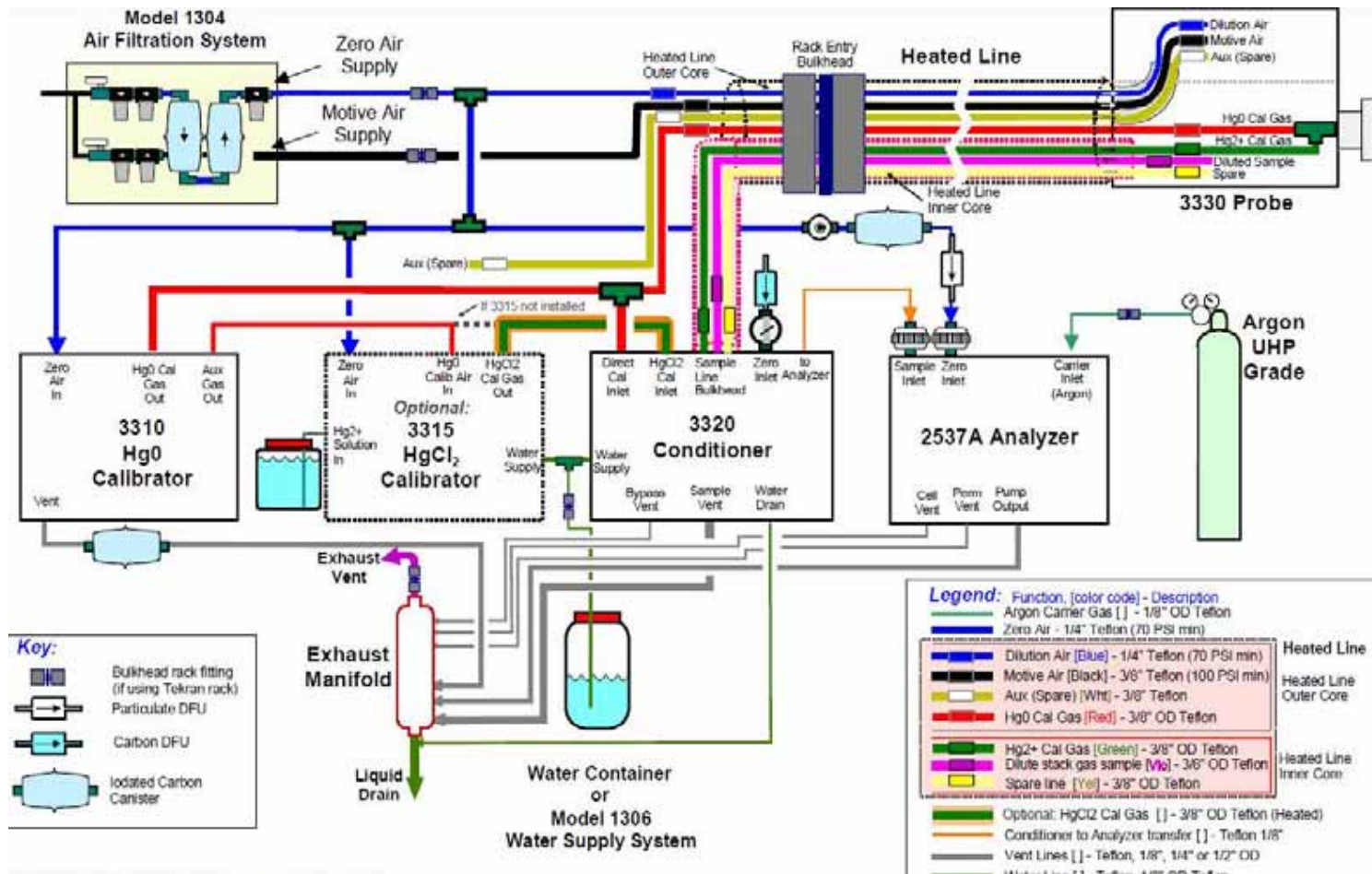

Simplicity

No on-site Hg calibration materials



Simplicity

Permanent systems install in 1-3 days

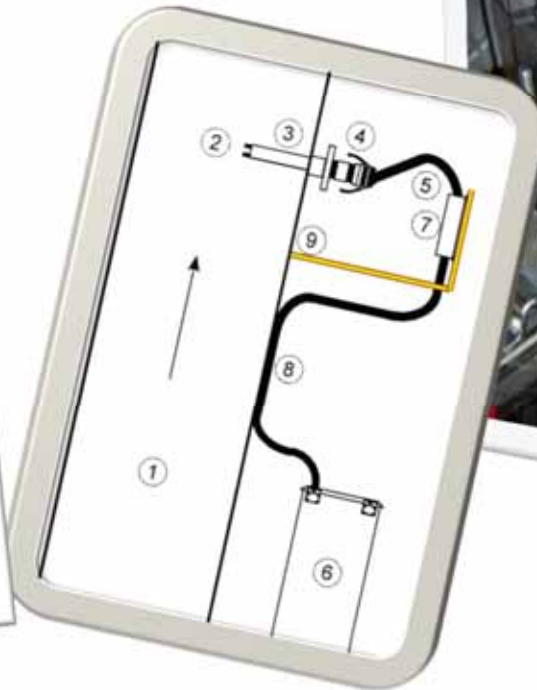

Certification Requirements

Hg CEMS versus STMMS

Hg CEMS

7-day calibration error test

Linearity test

3-level system integrity check

Cycle time test

RATA

4.1.2 *Sorbent Trap Monitoring Systems.*
For the initial certification of a sorbent trap monitoring system, only a RATA is required.

Certification Requirements

Hg CEMS versus STMMS

Hg CEMS	STMMS
7-day calibration error test	RATA
Linearity test	
3-level system integrity check	
Cycle time test	
RATA	

4.1.2 *Sorbent Trap Monitoring Systems.*
For the initial certification of a sorbent trap monitoring system, **only a RATA is required.**

NIST-Traceable

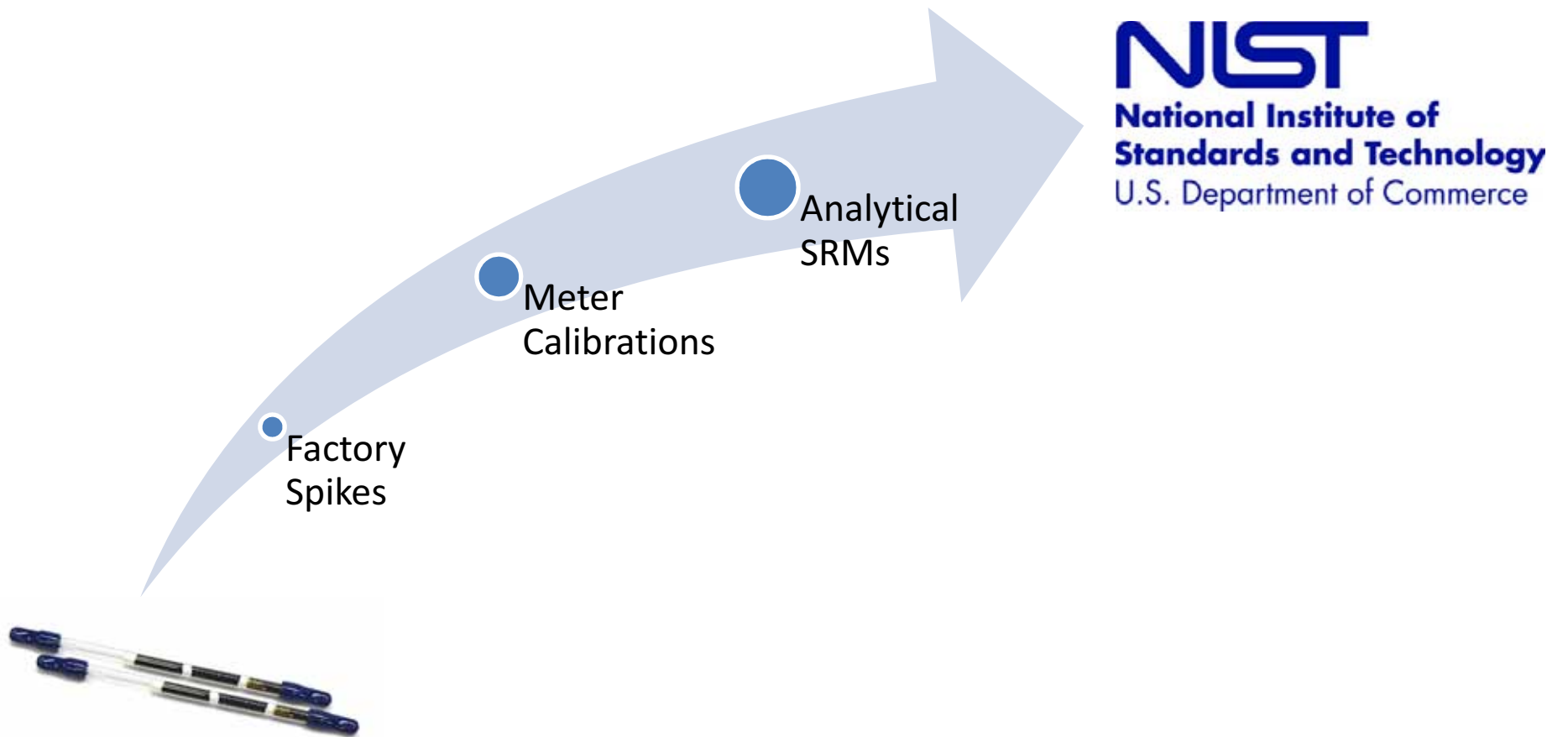

It works

- No Hg transport issues
- Very low MDL possible
- Built-in QA/QC

$$MDL = \frac{mdl_a}{\dot{Q}_{sample} \times Time}$$

It works

- No Hg transport issues
- Very low MDL possible
- Built-in QA/QC



✓ Spike recovery

✓ Breakthrough



✓ Paired trap agreement

✓ Proportional sampling

It's cost-effective

...but not cheap.

- Hardware about $\frac{1}{3}$ the cost of CEMS
- Operating costs about $\frac{1}{2}$ cost of CEMS

	Type	EPA Estimate ^b	Reality ^c
Capital Costs	CEMS	\$220,000	\$300-400,000
	Sorbent trap	N/A	\$100-150,000
Ongoing Costs ^d	CEMS	\$77,000	\$50-75,000
	Sorbent trap	N/A	\$20-30,000

^a Costs do not include stack or platform modifications

^b From EPA CEMS Cost Model 03/07/07 w/ 10% inflation adjustment to 2012

^c Vendor information

^d Annual Costs. Without capital recovery

MATS

Part UUUUU to read as follows:

Subpart UUUUU—National Emission Standards for Hazardous Air Pollutants: Coal- and Oil-Fired Electric Utility Steam Generating Units

Sec.

What This Subpart Covers

63.9980 What is the purpose of this subpart?

63.9981 Am I subject to this subpart?

63.9982 What is the affected source of this subpart?

or
63.9983 Are any EGUs not subject to this subpart?

63.9984 When do I have to comply with this subpart?

63.9985 What is a new EGU?

Emission Limitations and Work Practice Standards

2,
or
63.9990 What are the subcategories of EGUs?

63.9991 What emission limitations, work practice standards, and operating limits must I meet?

General Compliance Requirements

63.10039 How often and how long

I keep my records?

Other Requirements and Information

63.10040 What parts of the General Provisions apply to me?

63.10041 Who implements and enforces this subpart?

63.10042 What definitions apply to this subpart?

Tables to Subpart UUUUU of Part 63

Table 1 to Subpart UUUUU of Part 63—
Emission Limits for New or
Reconstructed EGUs

Table 2 to Subpart UUUUU of Part 63—
Emission Limits for Existing EGUs

Table 3 to Subpart UUUUU of Part 63—Work
Practice Standards

Table 4 to Subpart UUUUU of Part 63—
Operating Limits for EGUs

Table 5 to Subpart UUUUU of Part 63—
Performance Testing Requirements

Table 6 to Subpart UUUUU of Part 63—
Establishing PM CPMS Operating Limits

Table 7 to Subpart UUUUU of Part 63—
Demonstrating Continuous Compliance

Table 8 to Subpart UUUUU of Part 63—
Reporting Requirements

Table 9 to Subpart UUUUU of Part 63—
Applicability of General Provisions

MATS Requirements

New and existing coal, IGCC and petcoke EGU's will have to monitor mercury

- Measure total vapor-phase Hg
- Report units of standard (lb/TBtu and/or lb/GWh)



Nuances

- No missing data procedures
- No bias adjustment factor
- Startup and Shutdown
 - Possible LEE exemption

LEE Exemption

- Mercury, Avg < 10% of limit or PTE < 29 lb/yr
0.12 lb/Tbtu (0.0013 lb/GWh) for existing units, not low-rank coal
- 30-day stack test annually

Cannot claim LEE if:

- Scrubber with bypass,
or
- New Unit

MATS Hg Limits

$\mu\text{g}/\text{scm}$

Existing

New

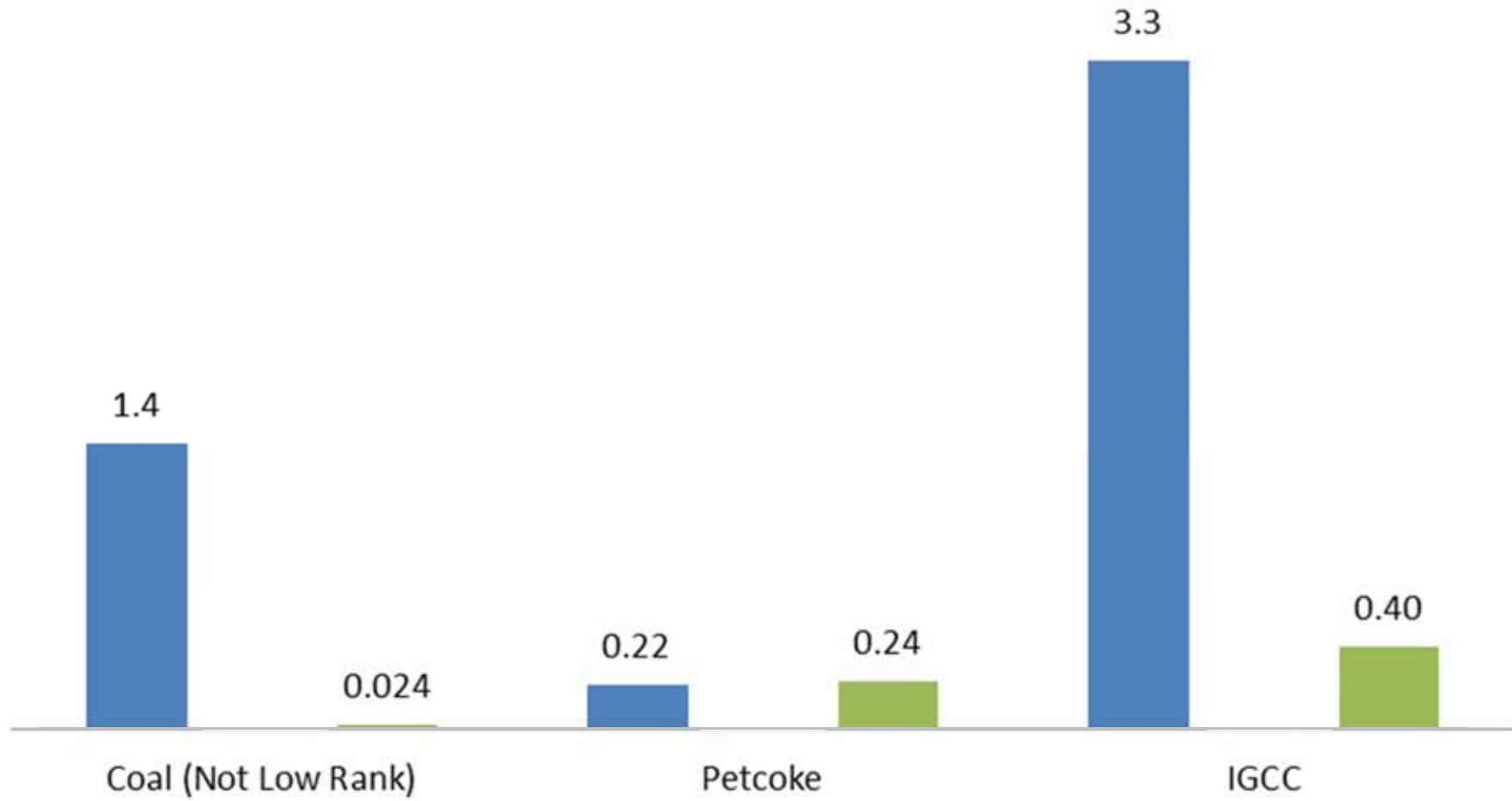

MATS Hg Limits

$\mu\text{g}/\text{scm}$

Existing LEE New

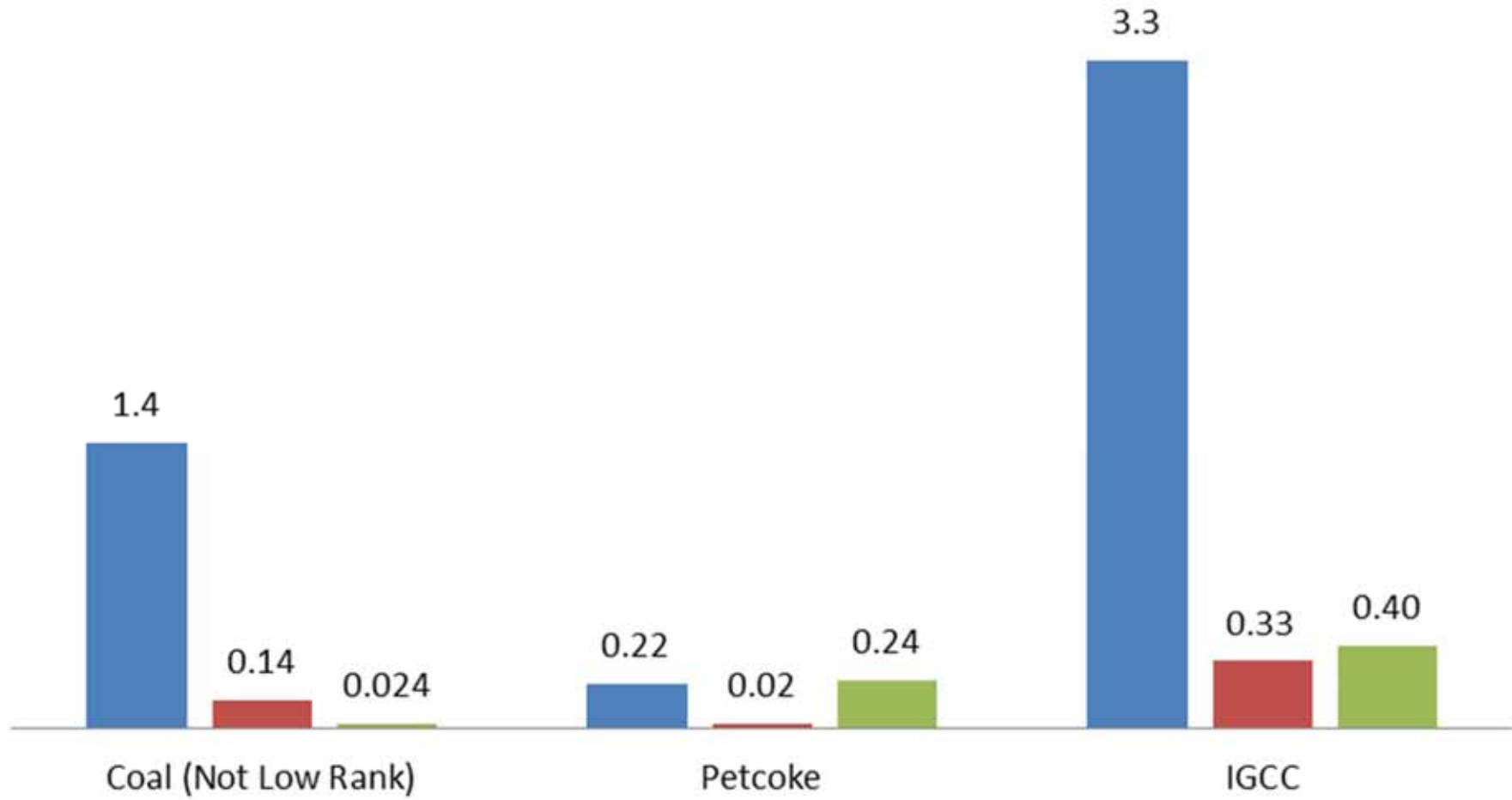

MATS Hg Limits

$\mu\text{g}/\text{scm}$

Existing LEE New

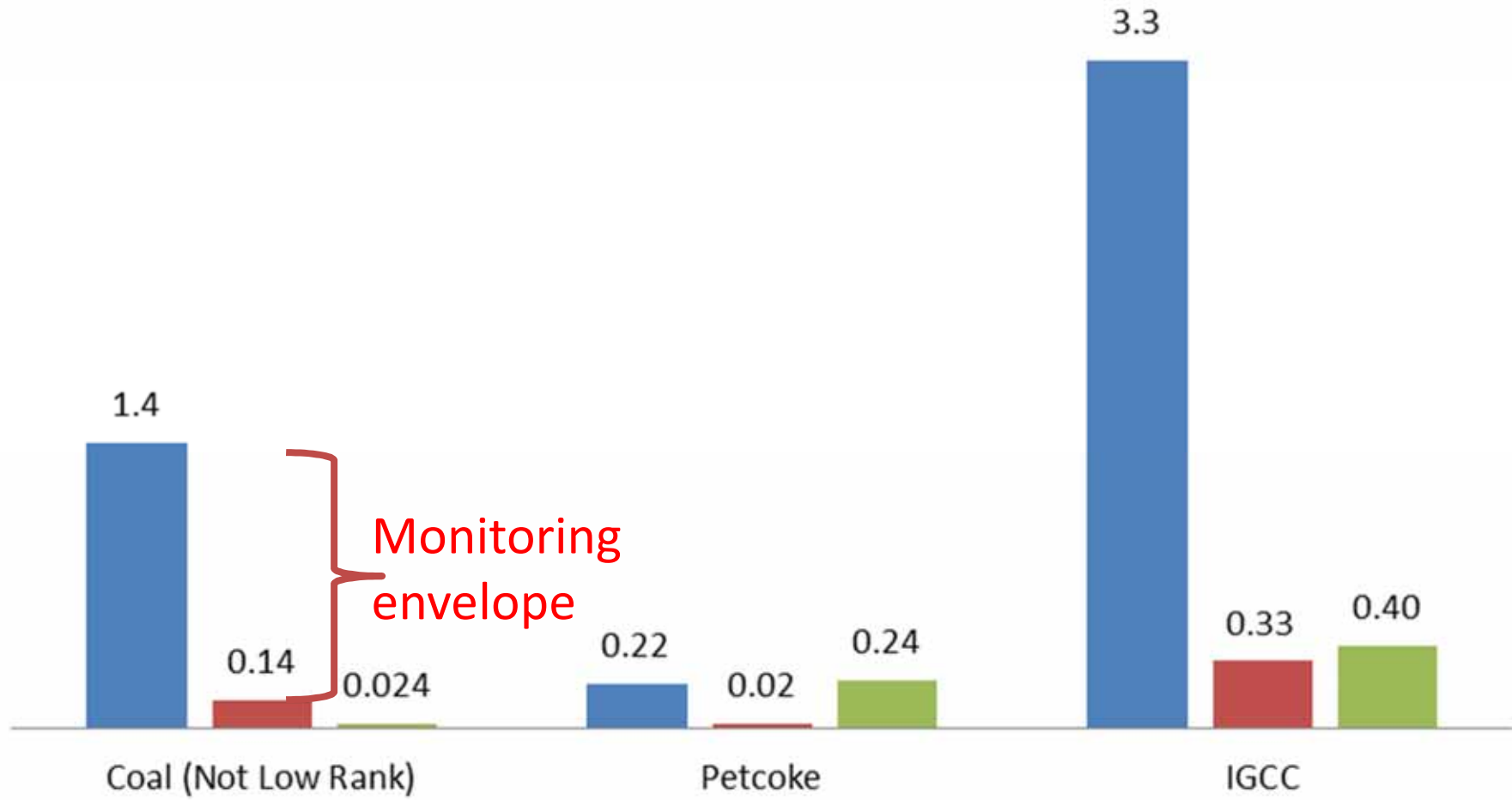

Sorbent trap monitoring at ridiculously low levels...

- How accurate is it?
- How reproducible is it?
- How reliable is it?
- How low can we go?

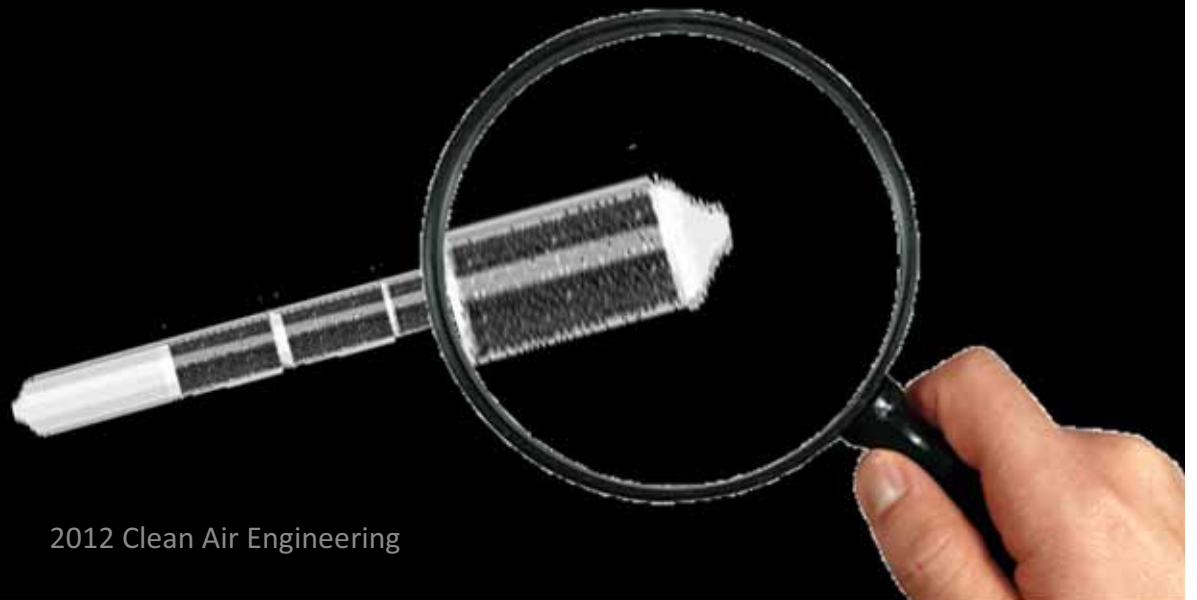

Accuracy

Run*	Hg conc. (µg/dscm)		DIFF	%DIFF
	RM	MET80		
	C _{RM - Avg}	C _{CMMS-AVG}		
1-1	0.21	0.18	0.03	14.3%
1-2	0.18	0.18	0.00	-0.6%
1-3	0.19	0.18	0.01	7.4%
1-4	0.16	0.21	-0.05	-29.4%
1-5	0.25	0.20	0.05	21.2%
1-6	0.24	0.22	0.02	10.0%
2-1	0.26	0.29	-0.03	-9.6%
2-2	0.30	0.28	0.02	8.0%
2-3	0.24	0.27	-0.03	-13.8%
2-4	0.26	0.27	-0.01	-5.4%
2-5	0.25	0.27	-0.02	-8.4%
<i>All data (n=11)</i>	0.231	0.231	0.0004 0.021 9.2%	

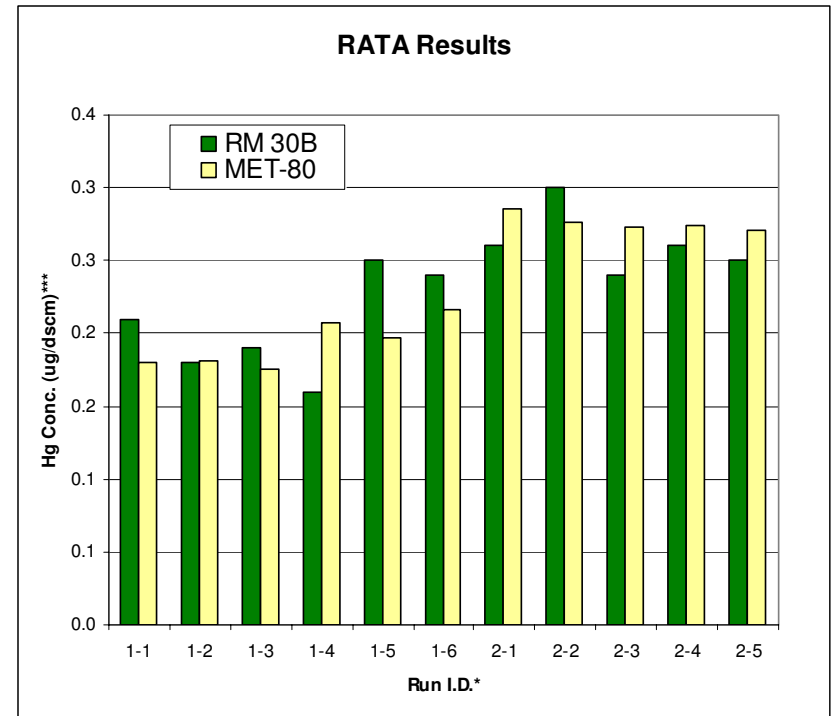

Accuracy

Run*	Hg conc. (µg/dscm)		DIFF	%DIFF
	RM	MET80		
	$C_{RM - Avg}$	$C_{CMMS-AVG}$		
1-1	0.21	0.18	0.03	14.3%
1-2	0.18	0.18	0.00	-0.6%
1-3	0.19	0.18	0.01	7.4%
1-4	0.16	0.21	-0.05	-29.4%
1-5	0.25	0.20	0.05	21.2%
1-6	0.24	0.22	0.02	10.0%
2-1	0.26	0.29	-0.03	-9.6%
2-2	0.30	0.28	0.02	8.0%
2-3	0.24	0.27	-0.03	-13.8%
2-4	0.26	0.27	-0.01	-5.4%
2-5	0.25	0.27	-0.02	-8.4%
<i>All data (n=11)</i>	0.231	0.231	0.0004	9.2%

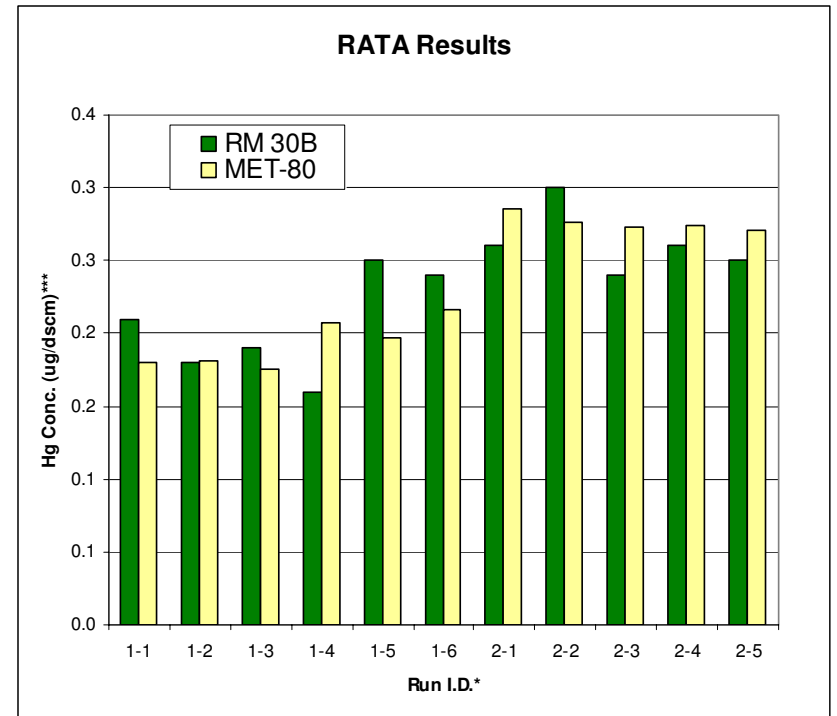

Reproducibility

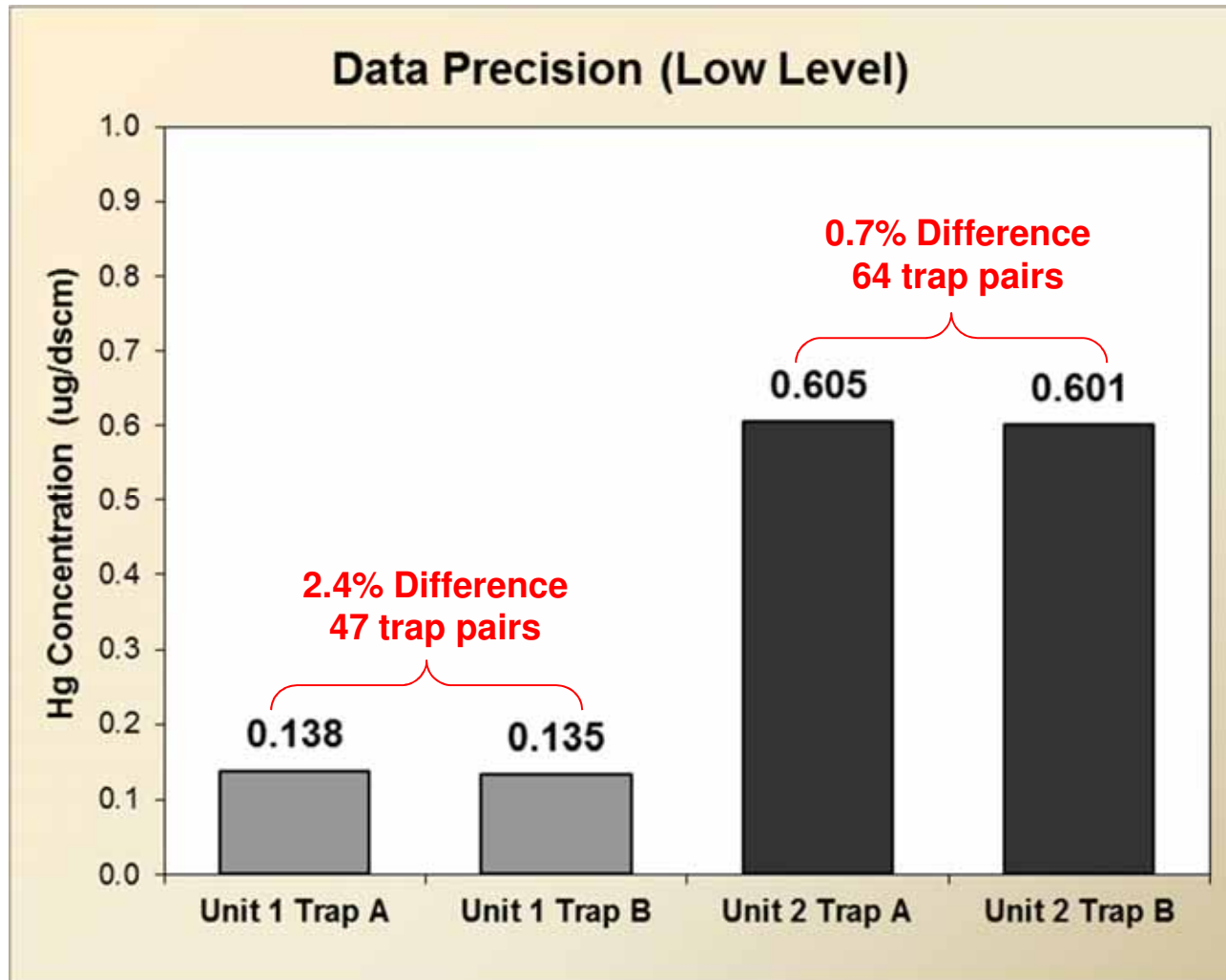

Reliability

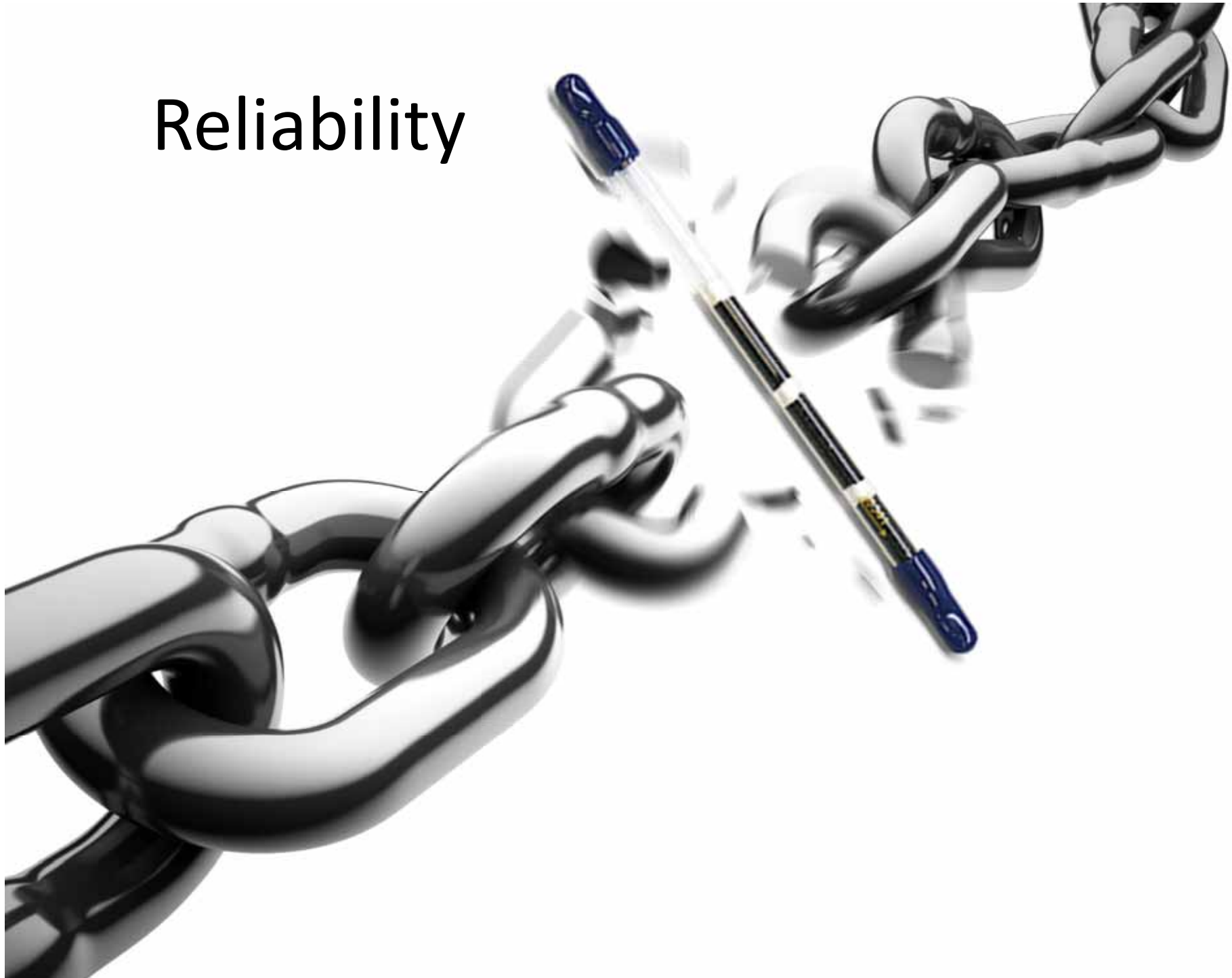

Reliability

Case study

- Dominion Salem Harbor
- Compliance monitoring since 2008
- Three MET-80 systems



MET-80 Data Validity – Unit 1

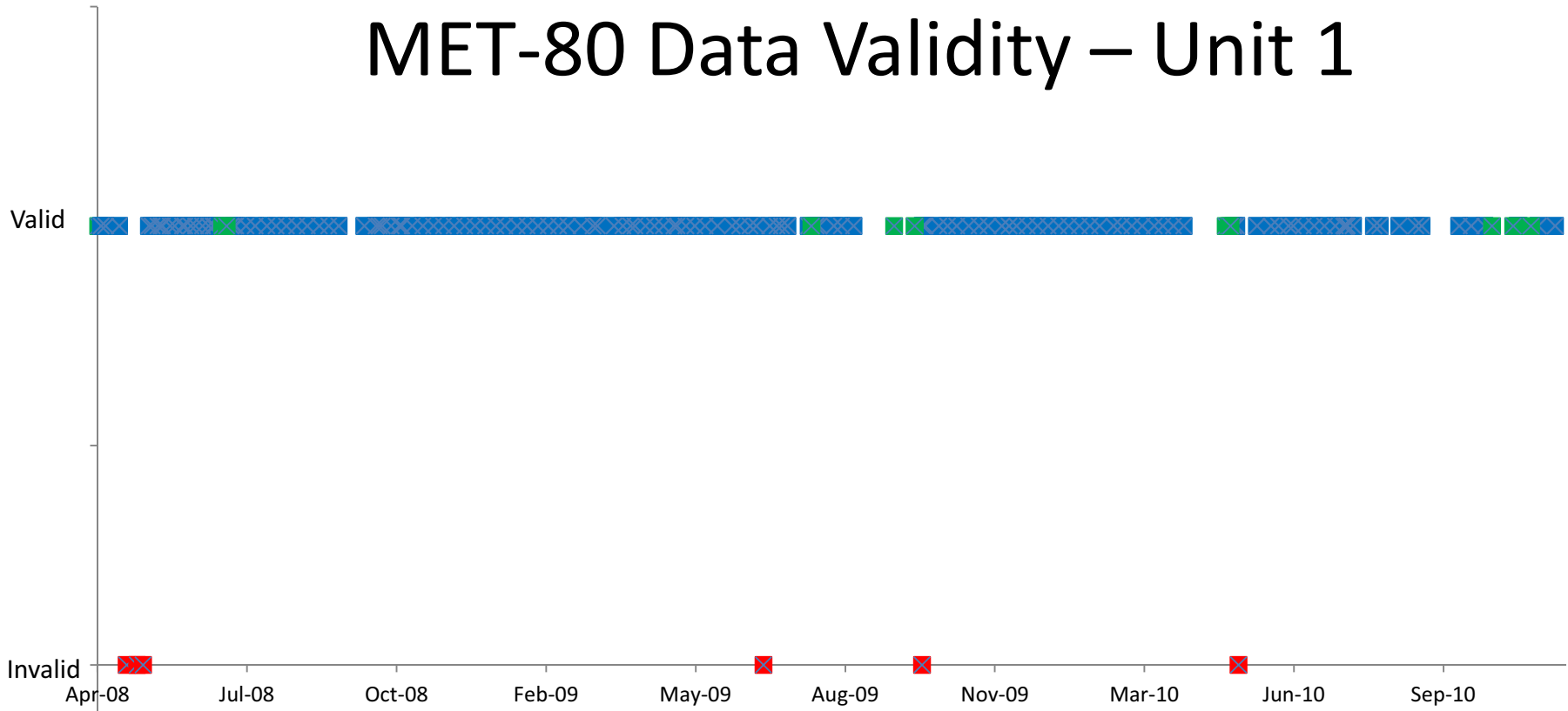

MET-80 Data Validity – Unit 1

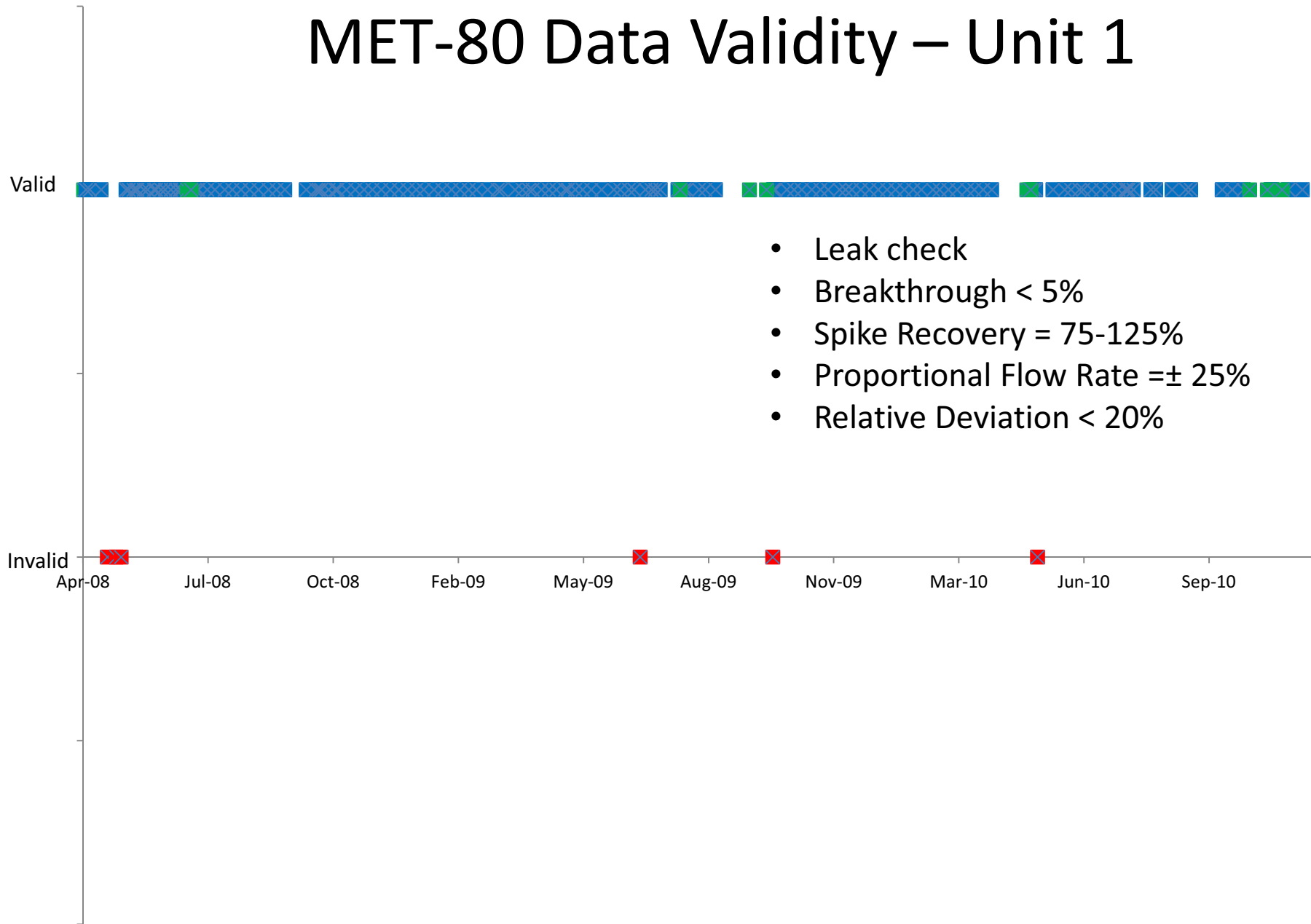

MET-80 Data Validity – Unit 1

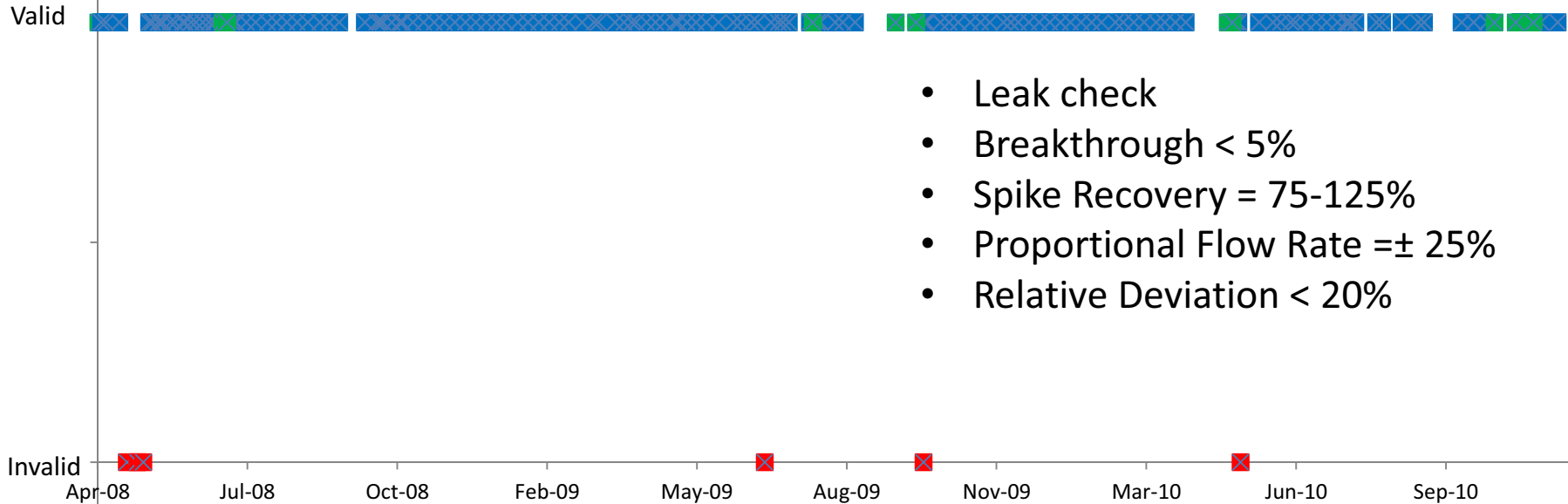

94%
reported
availability

MET-80 Data Validity – Unit 1

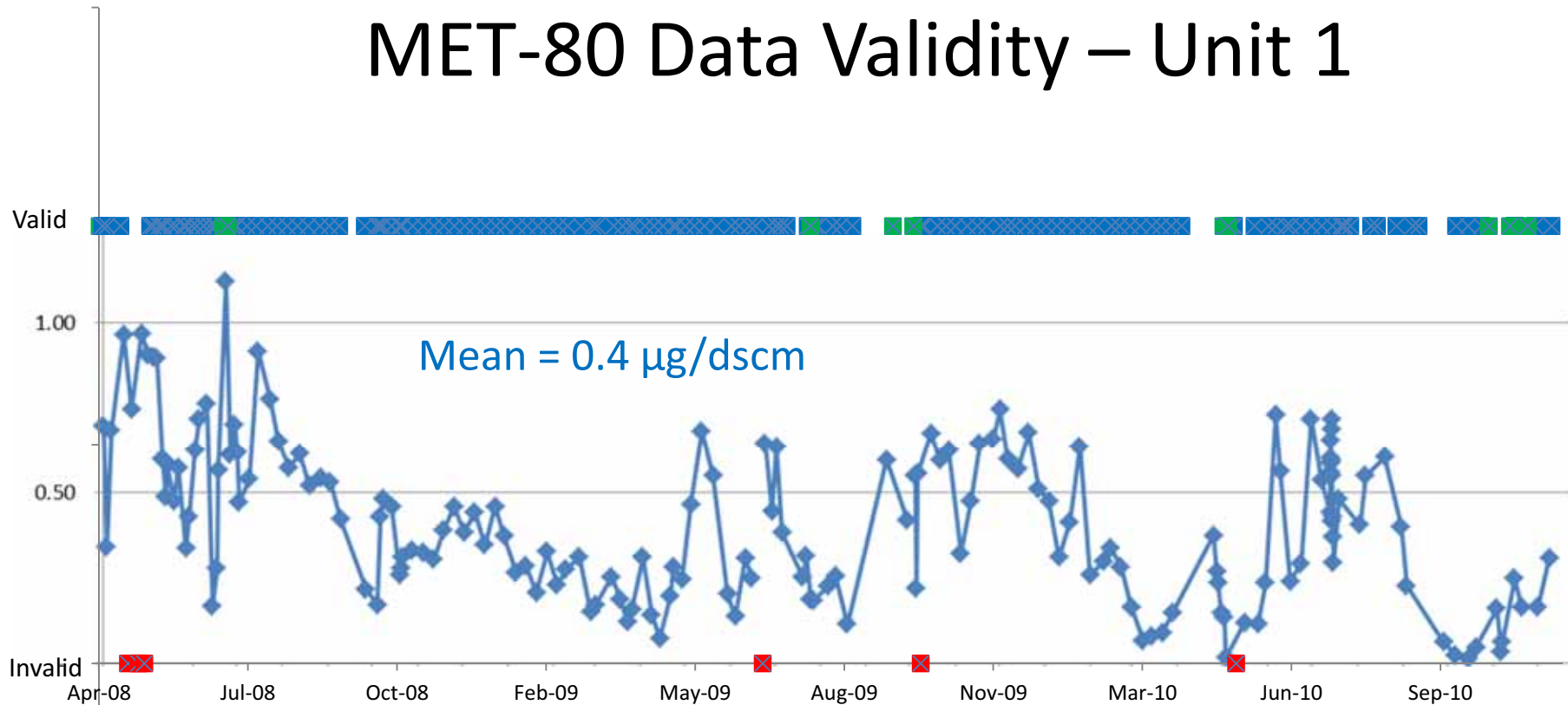

94%
reported
availability

MET-80 Data Validity – Unit 2

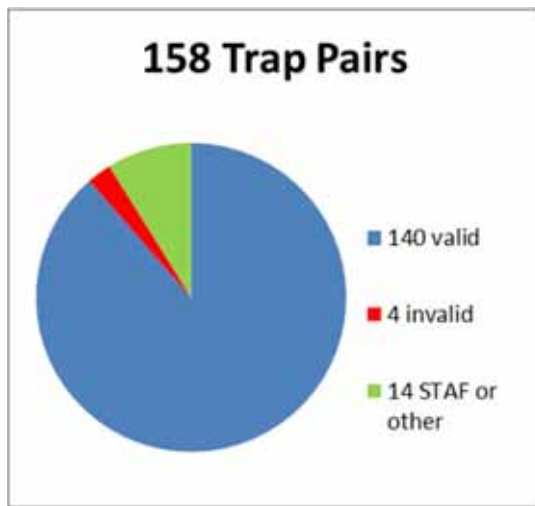
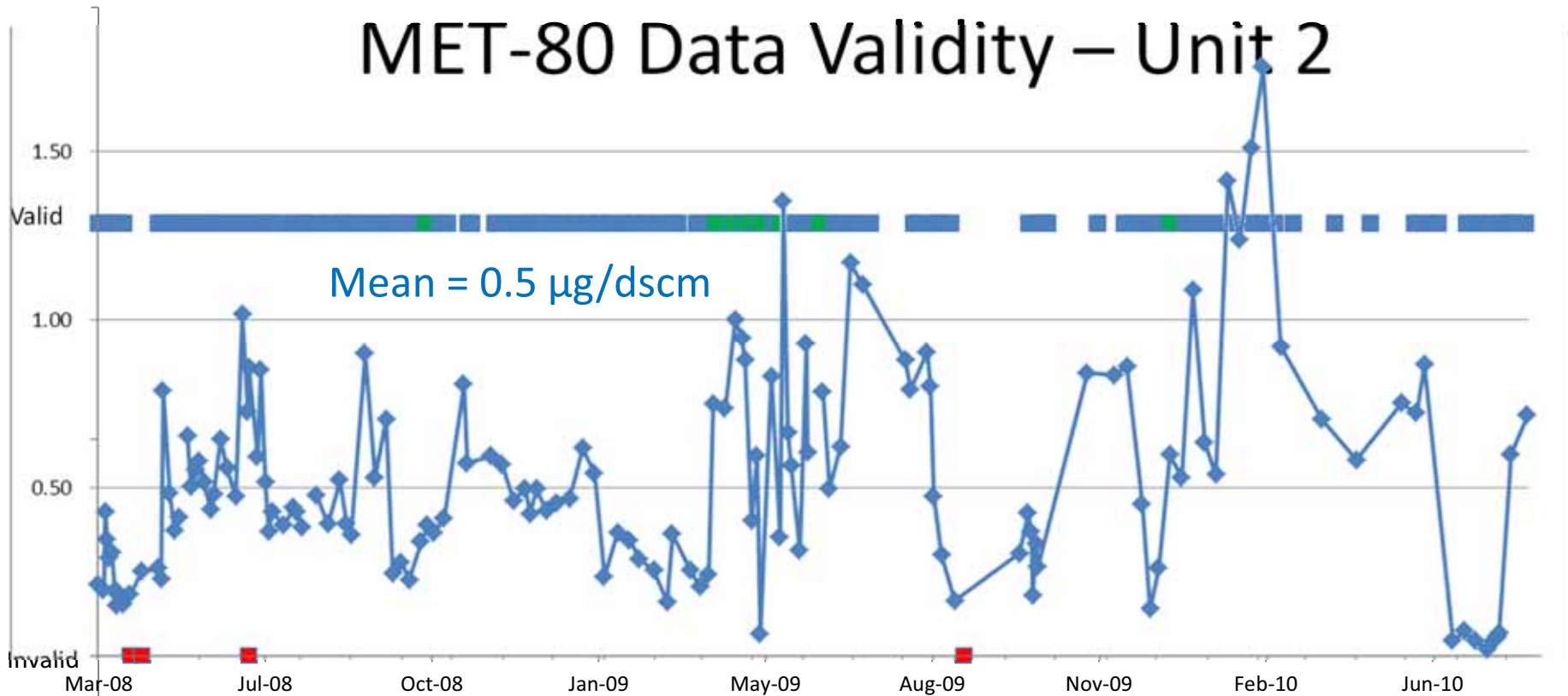

91%
reported
availability

MET-80 Data Validity – Unit 3

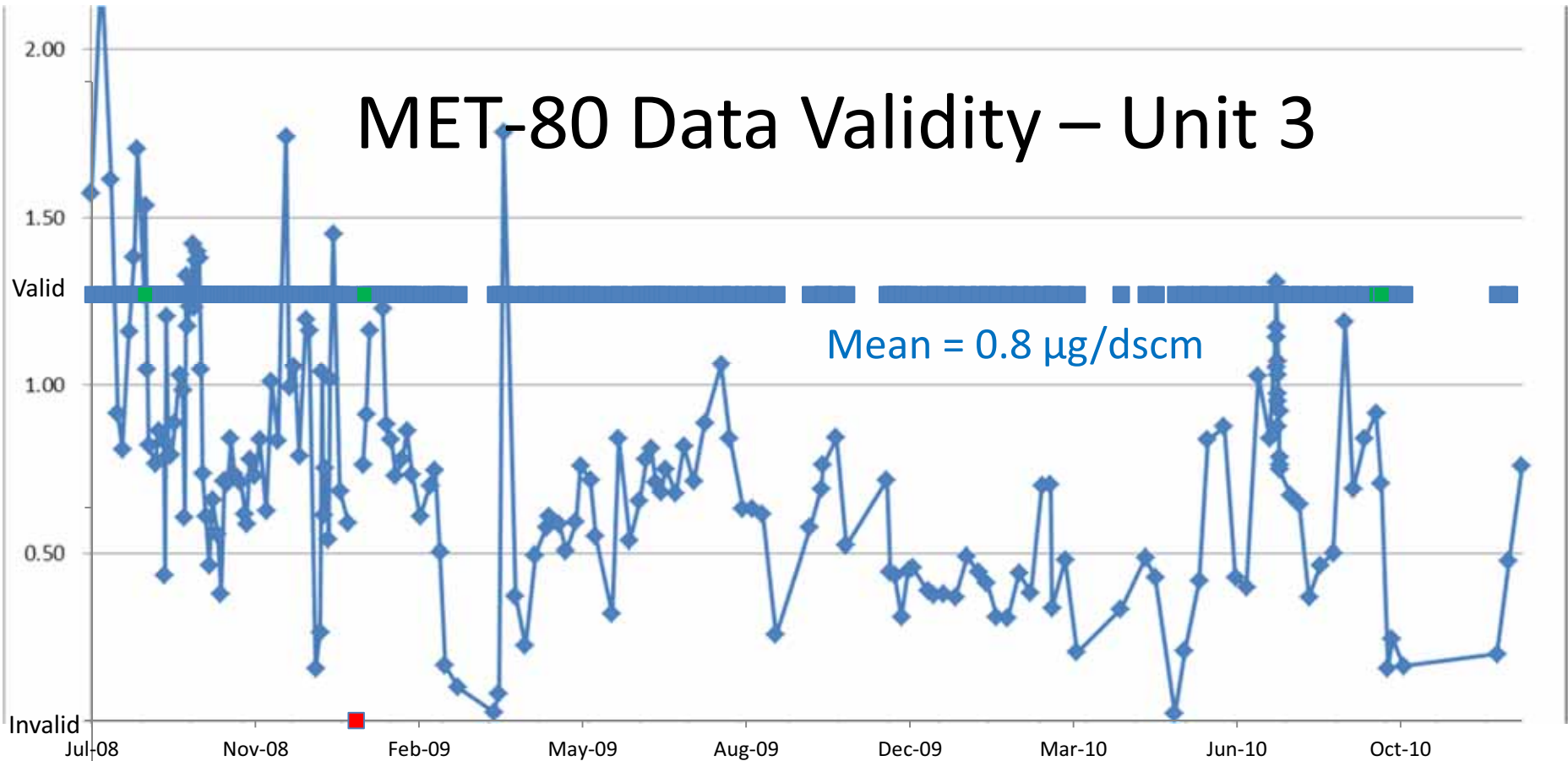

96%
reported
availability

How low can we go?

MATS Hg Limits

$\mu\text{g}/\text{scm}$

Existing

New

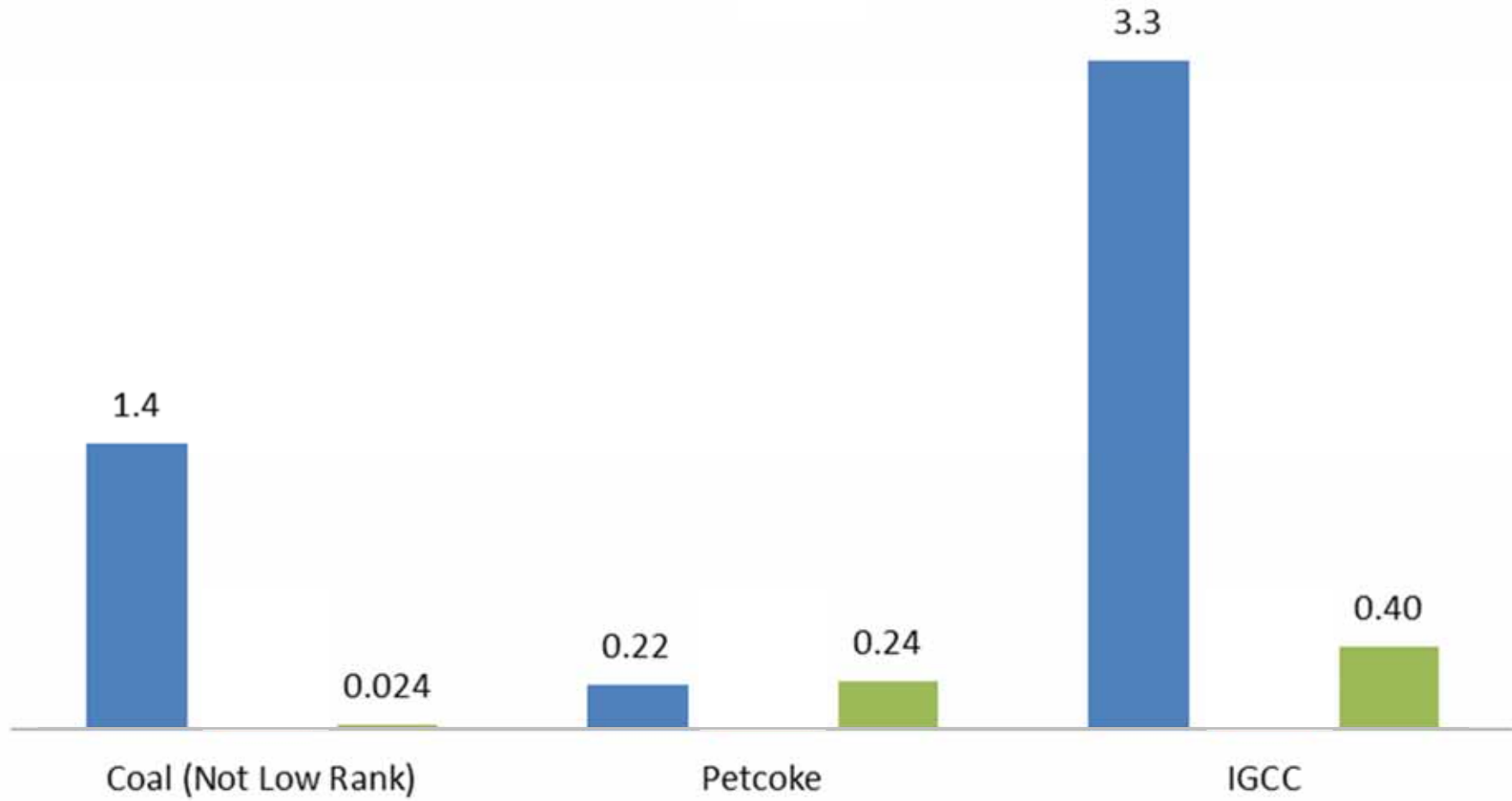

MATS Hg Limits

$\mu\text{g}/\text{scm}$

Existing

New

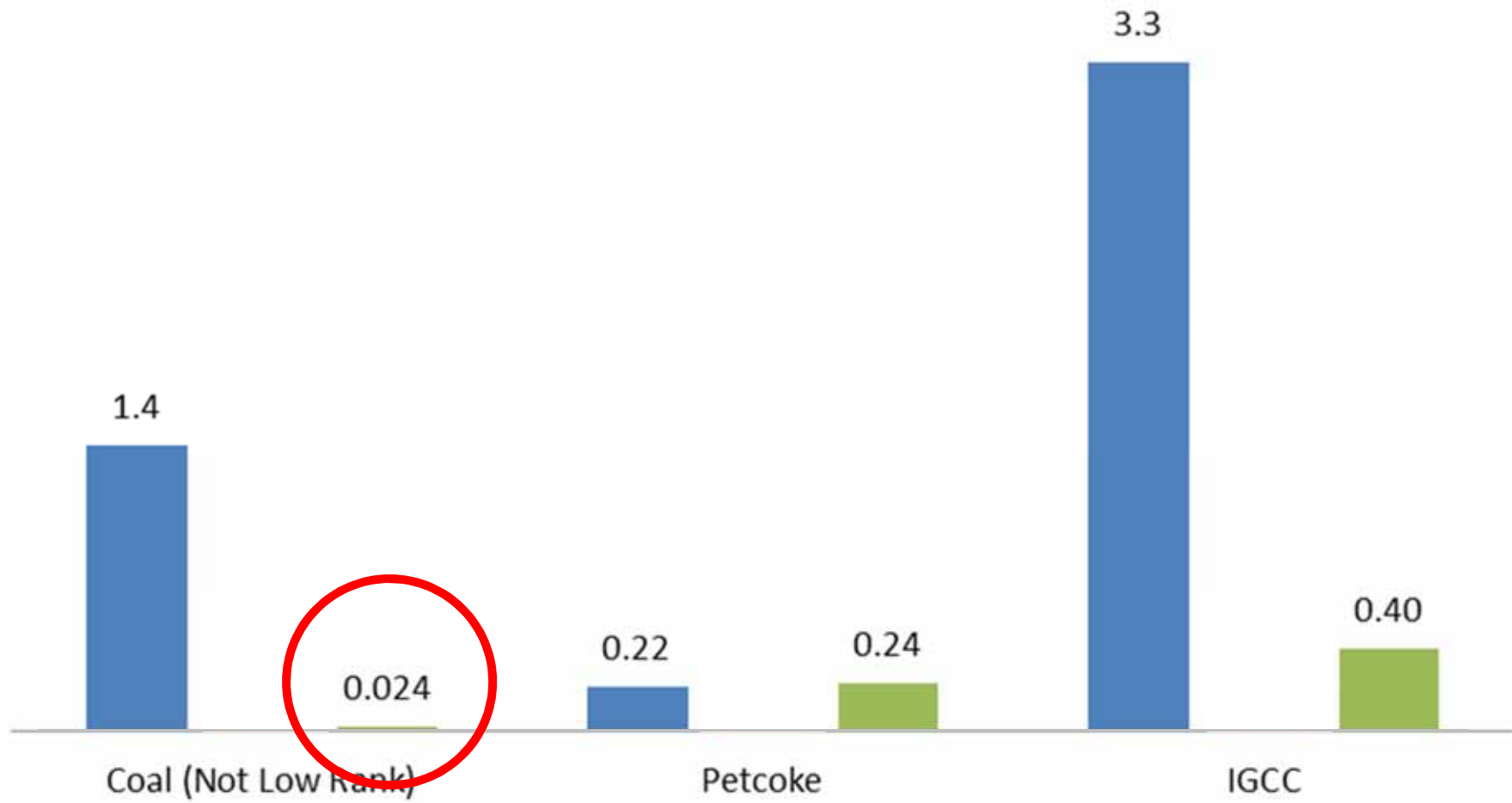

Western Bituminous

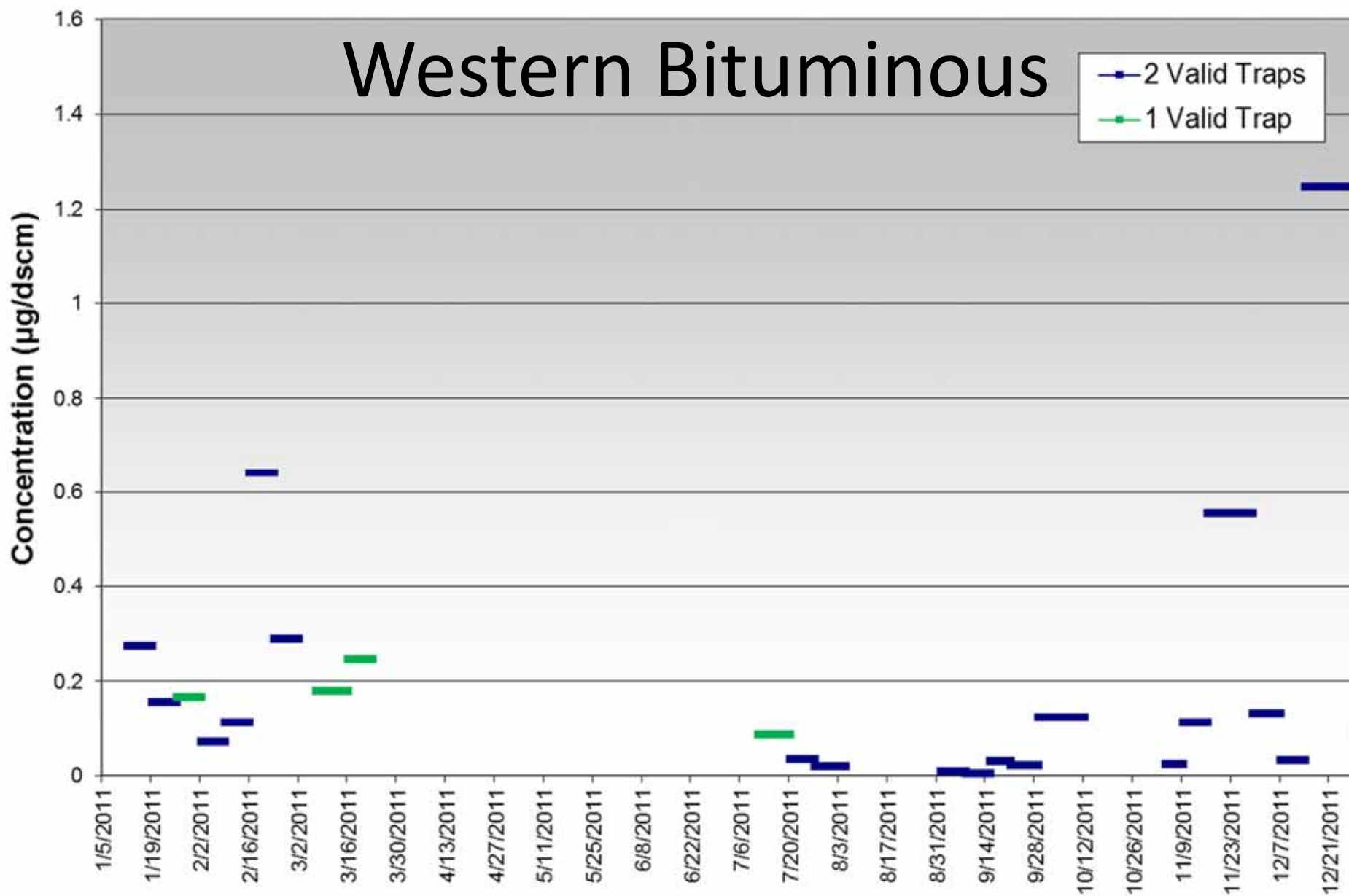

Date

2012 Clean Air Engineering

Western Bituminous

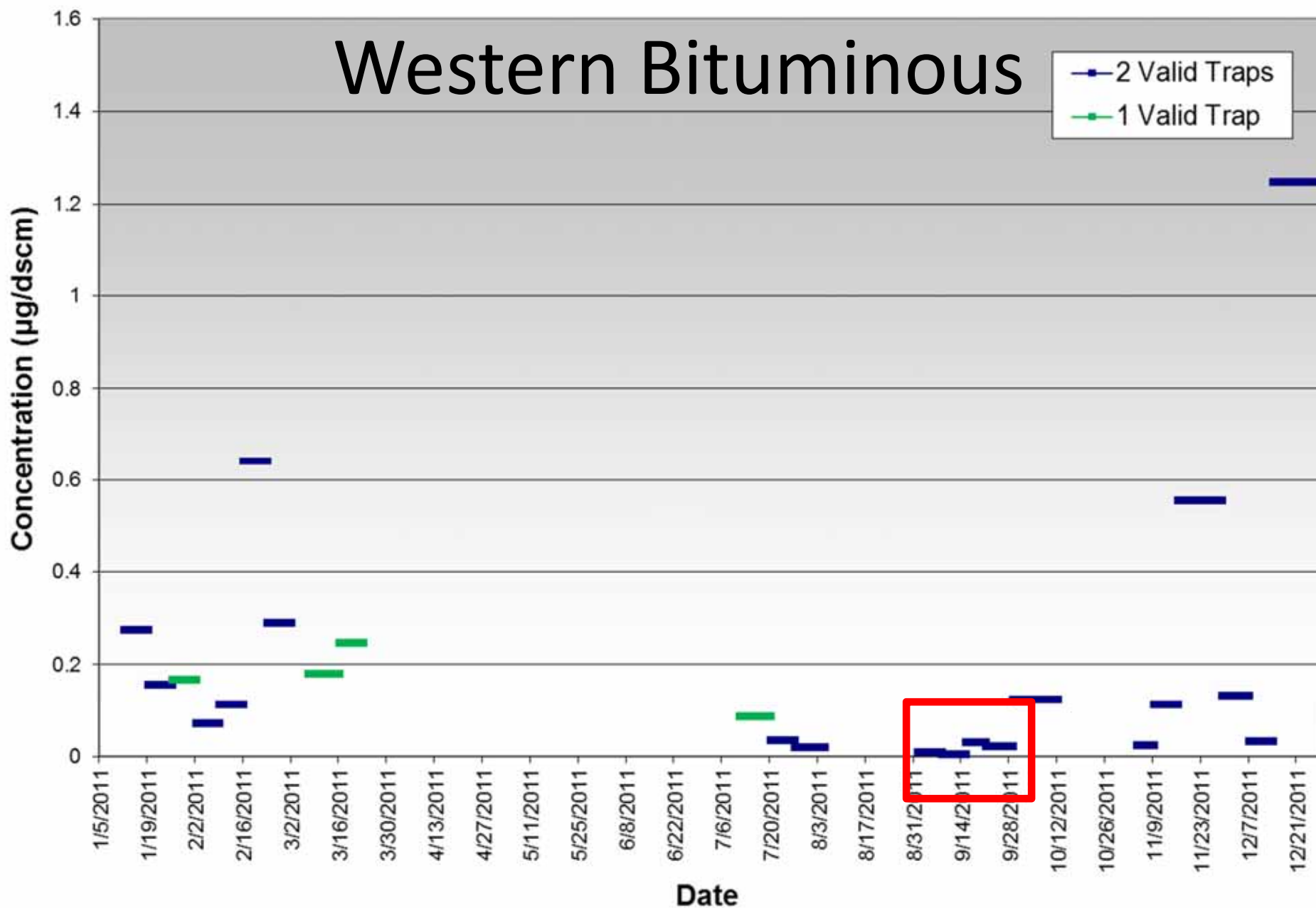

0 – 0.025 $\mu\text{g}/\text{scm}$

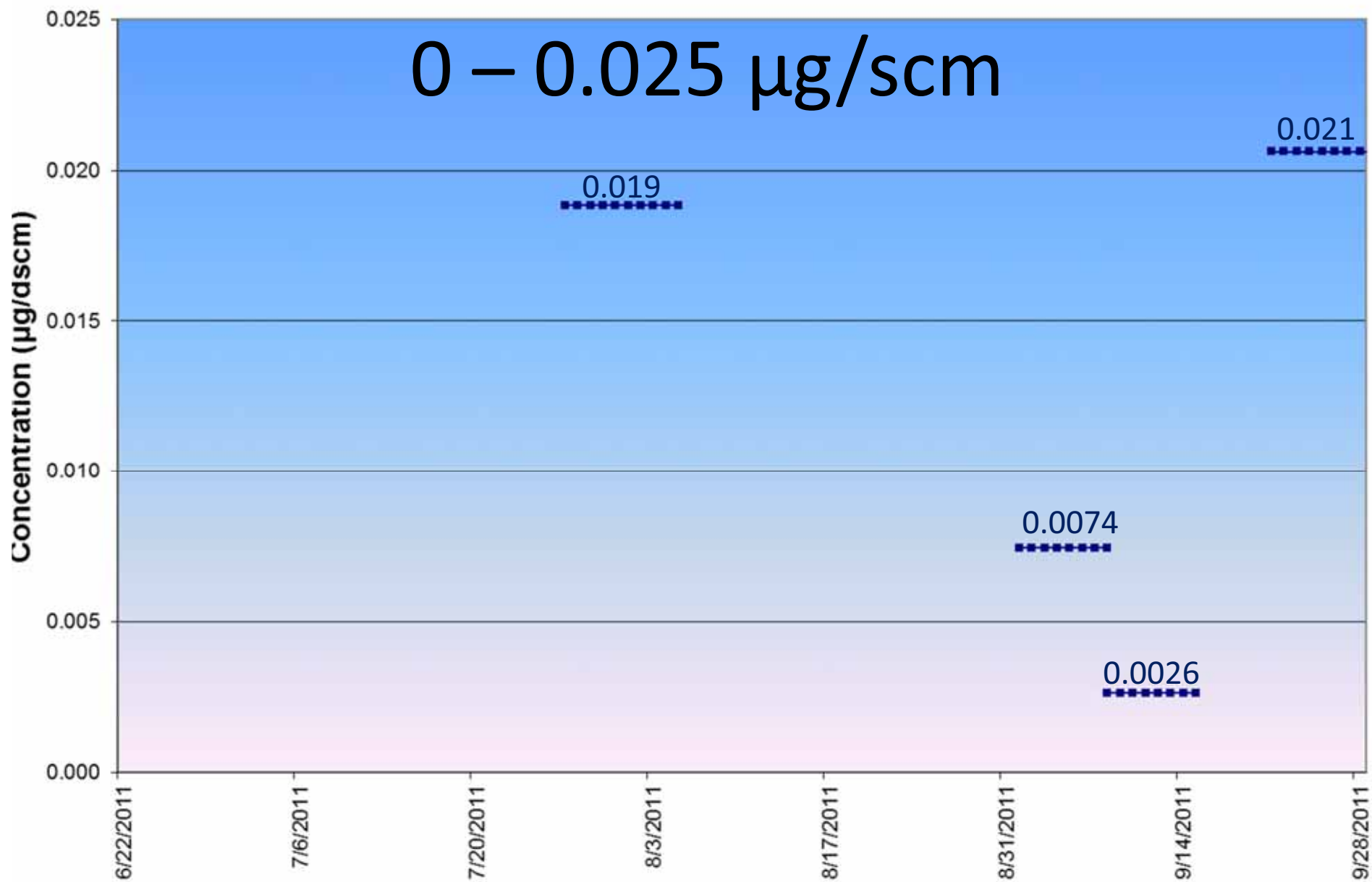

Take away

- MATS will require mercury measurements well below 1 $\mu\text{g}/\text{scm}$

Take away

- MATS will require mercury measurements well below 1 $\mu\text{g}/\text{scm}$
- These levels can be measured

Take away

- MATS will require mercury measurements well below 1 $\mu\text{g}/\text{scm}$
- These levels can be measured
- Existing units:

Take away

- MATS will require mercury measurements well below 1 $\mu\text{g}/\text{scm}$
- These levels can be measured
- Existing units: **sorbent trap monitoring or CEMS**

Take away

- MATS will require mercury measurements well below 1 $\mu\text{g}/\text{scm}$
- These levels can be measured
- Existing units: sorbent trap monitoring or CEMS
- New units:

Take away

- MATS will require mercury measurements well below 1 $\mu\text{g}/\text{scm}$
- These levels can be measured
- Existing units: sorbent trap monitoring or CEMS
- New units: sorbent trap monitoring

Questions?

9496 Federal Register / Vol. 77, No. 32 / Thursday, February 16, 2012 / Rules and Regulations

TABLE 5 TO SUBPART UUUUU OF PART 63—PERFORMANCE TESTING REQUIREMENTS—Continued
 [As stated in § 63.10007, you must comply with the following requirements for performance testing for existing, new or reconstructed affected sources.]

To conduct a performance test for the following pollutant . . .	Using . . .	You must perform the following activities, as applicable to your input- or output-based emission limit . . .	Using . . .
	OR	f. Convert emissions concentration to lb/TBtu or lb/GWh emission rates. OR Hg CEMS a. Install, certify, operate, and maintain the CEMS. b. Install, certify, operate, and maintain the diluent gas, flow rate, and/or moisture monitoring systems. c. Convert hourly emissions concentrations to 30 boiler operating day rolling average lb/TBtu or lb/GWh emission rates.	Method 19 F-factor methodology at Appendix A-7 to part 60 of this chapter, or calculate using mass emissions rate and electrical output data (see § 63.10007(e)). Sections 3.2.1 and 5.1 of Appendix A of this subpart. Part 75 of this chapter and §§ 63.10010(a), (b), (c), and (d). Section 6 of Appendix A to this subpart.
	OR Sorber trap monitoring system.	OR a. Install, certify, operate, and maintain the sorber trap monitoring system. b. Install, operate, and maintain the diluent gas, flow rate, and/or moisture monitoring systems	Sections 3.2.2 and 5.2 of Appendix A to this subpart. Part 75 of this chapter and §§ 63.10010(a), (b), (c), and (d).

cleanair.com
 contact@cleanair.com
 800-632-1619

Sorbent Trap 101



Sorbent Trap 101

- Total mercury *vapor*

- Elemental vapor

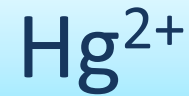

- Oxidized (Ionic) vapor



- Sometimes...Particle-bound - Hg_p
- Iodated activated carbon
- Paired sampling
- Atomic spectrometry analysis

The Journey

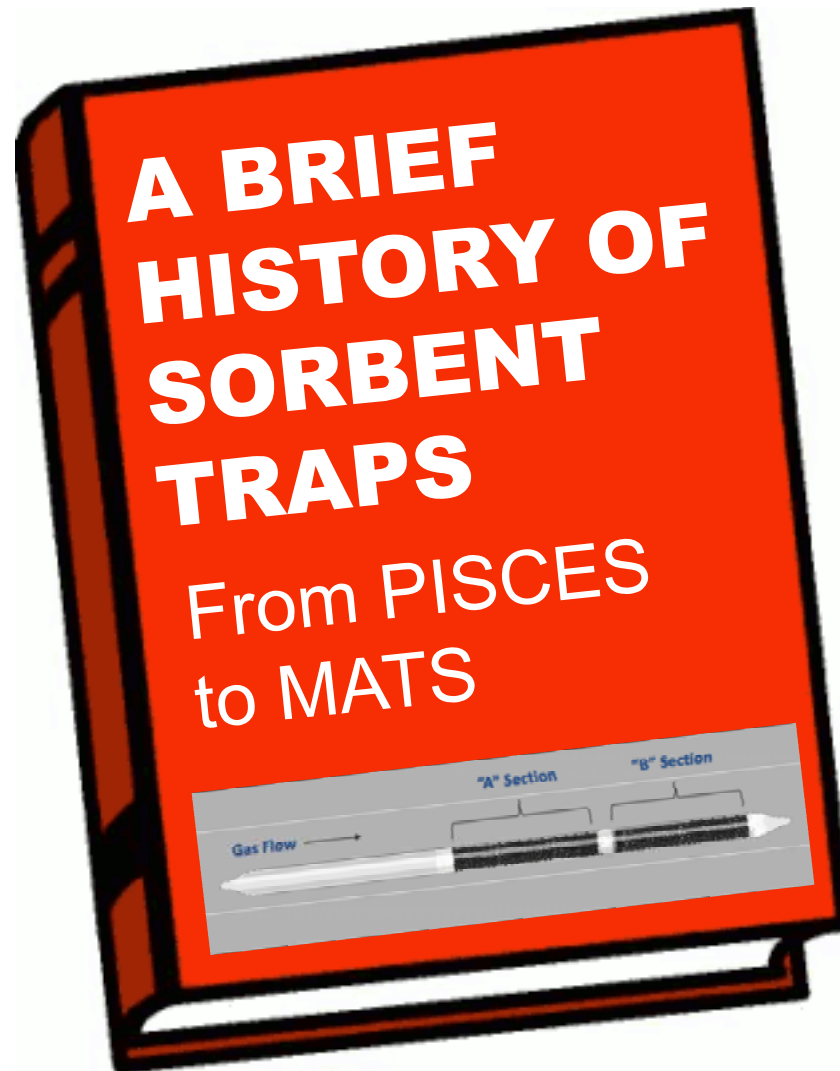

The Journey

- 20 years in the making
- MESA
- FAMS
- QSEM
- EPA Method
- Part 75 Air
- Part 60 M
- Appendix

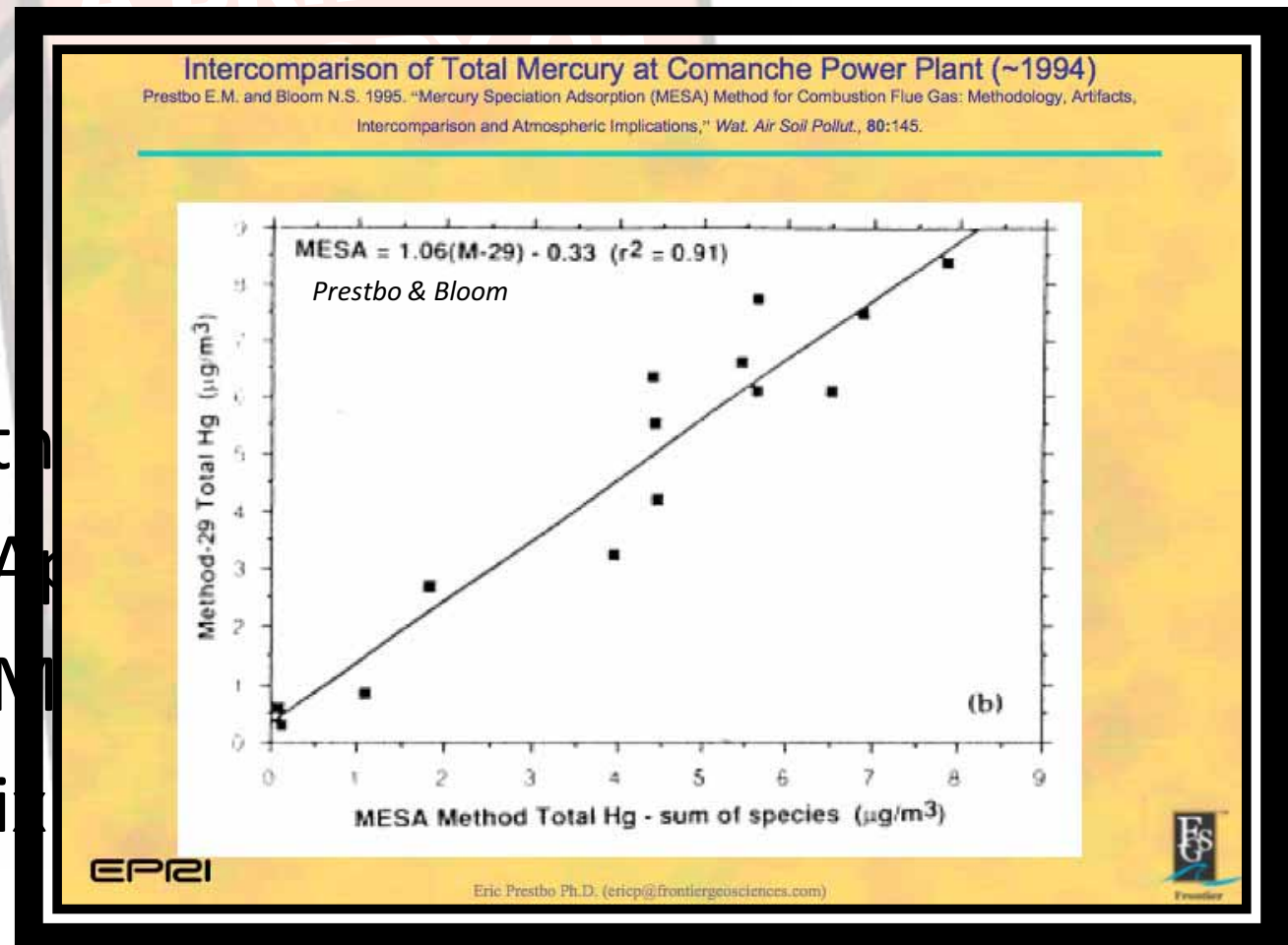

Players



U.S. DEPARTMENT OF
ENERGY



EPRI | ELECTRIC POWER
RESEARCH INSTITUTE



METHOD 30B – DETERMINATION OF TOTAL VAPOR PHASE MERCURY EMISSIONS FROM COAL-FIRED COMBUSTION SOURCES USING CARBON SORBENT TRAPS

1.0 Scope and Application

What is Method 30B?

Method 30B is a procedure for measuring total vapor phase mercury (Hg) emissions from coal-fired combustion sources using sorbent trap sampling and an extractive or thermal analytical technique. This method is only intended for use only under relatively low particulate conditions (e.g., sampling after all pollution control devices). Quality assurance and quality control requirements are included to assure that you, the tester, collect data of known and acceptable quality for each testing program. This method does not completely describe all equipment, supplies, and sampling and

Method 30B Traps

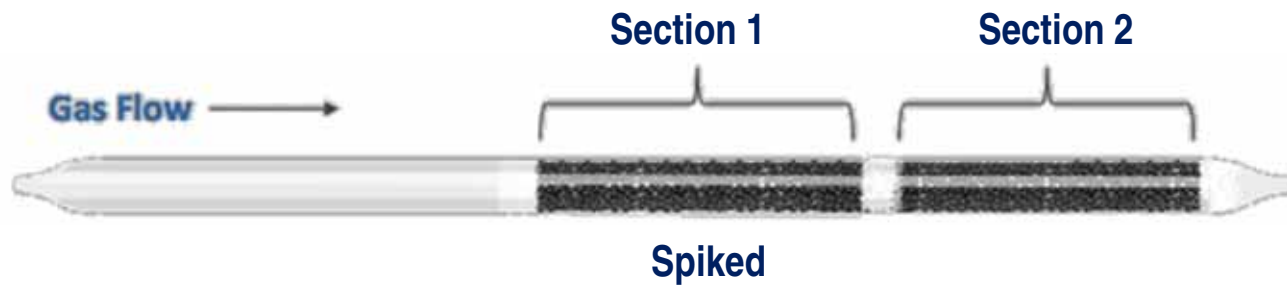

Sampling

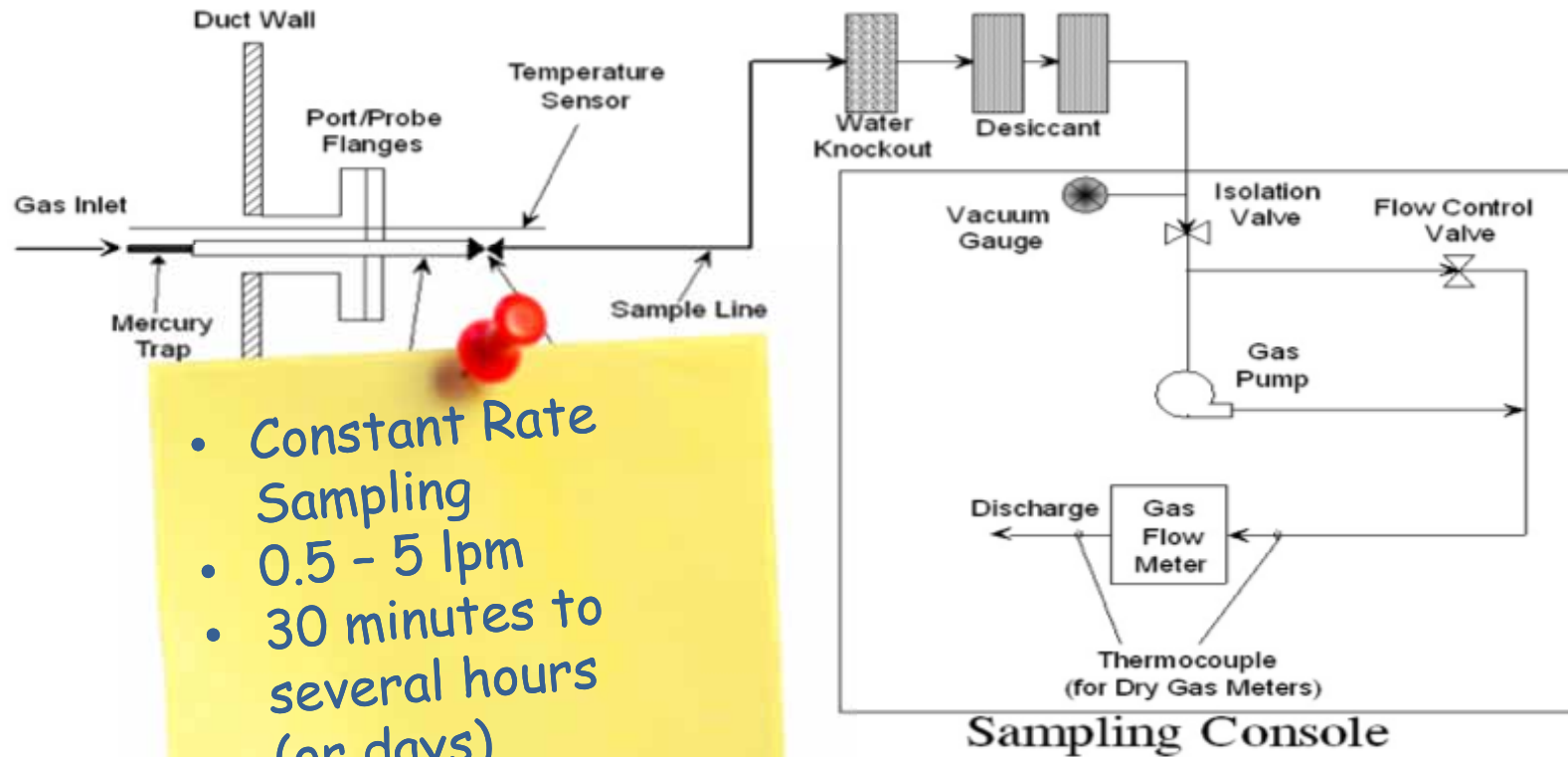

- Constant Rate Sampling
- 0.5 - 5 lpm
- 30 minutes to several hours (or days)
- Dry gas meter

Analysis

11.0 Analytical Procedures

The analysis of Hg in the field and quality control samples may be conducted using any instrument or technology capable of quantifying total Hg from the sorbent media and meeting the performance criteria in this method. Because multiple analytical approaches, equipment and techniques are appropriate for the analysis of sorbent traps, it is not possible to provide detailed, technique-specific analytical procedures. As they

1. Extraction
2. Analysis

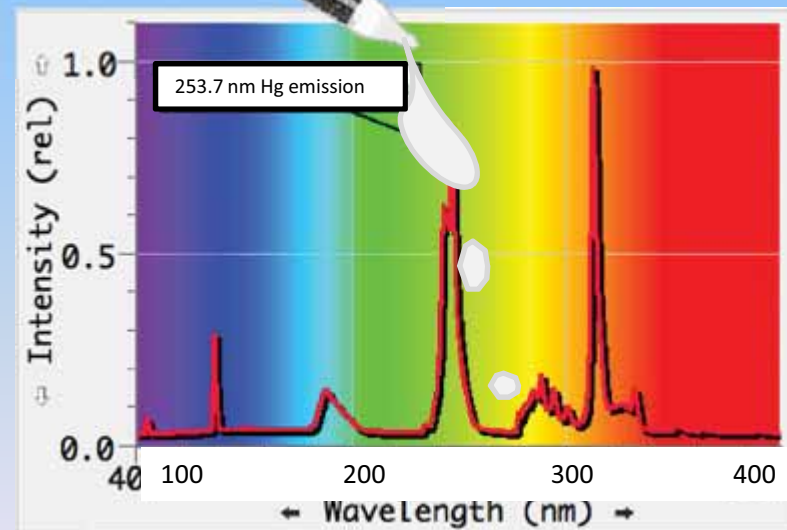

3.9 *Thermal Analysis*

means an analytical technique where the contents of the sorbent traps are analyzed using a thermal technique (desorption or combustion) to release the captured Hg in a detectable form for quantification.

3.10 *Wet Analysis* means

an analytical technique where the contents of the sorbent tube are first leached or digested to quantitatively transfer the captured Hg to liquid solution for subsequent analysis.

Analysis – Thermal



Ohio Lumex Company, 2012

Thermal Mercury Analyzers

Ohio Lumex 915+ with RP-M324

Teledyne Leeman Labs Hydra II C

LECO AMA254

Milestone, Inc. DMA-80

Nippon Instruments MA-3000

Analysis – Wet



Brooks Rand Labs, 2012

Analyses

- Atomic fluorescence spectrometry (EPA Method 1631, Revision E)
- Atomic absorption spectrometry (EPA Method 7473)
- Gold amalgamation
- Zeeman-corrected AAS



Sorbent Trap 102 Monitoring

Performance Specification 12B - Specifications and Test Procedures For Monitoring Total Vapor Phase Mercury Emissions from Stationary Sources Using a Sorbent Trap Monitoring System

1.0 Scope and Application

The purpose of Performance Specification 12B (PS 12B) is to establish performance benchmarks for, and to evaluate the acceptability of, sorbent trap monitoring systems used to monitor total vapor-phase mercury (Hg) emissions in stationary source flue gas streams. These monitoring systems involve continuous repetitive in-stack sampling using paired sorbent media traps with periodic analysis of the time-integrated samples. Persons using PS 12B should have a thorough working knowledge of Methods 1, 2, 3, 4, 5 and 30B in appendices A-1 through A-3 and A-8 to this part.

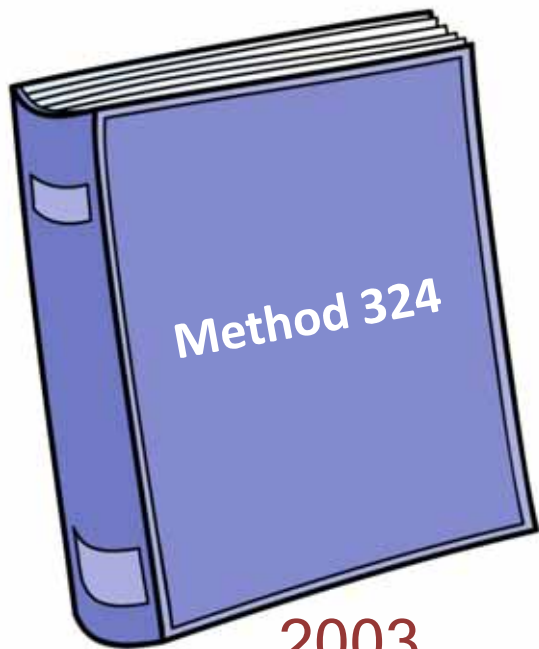

2003
EU MACT

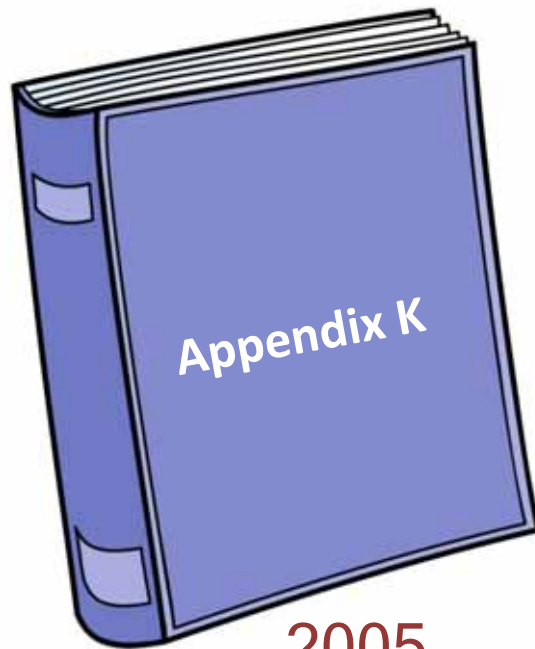

2005
CAMR

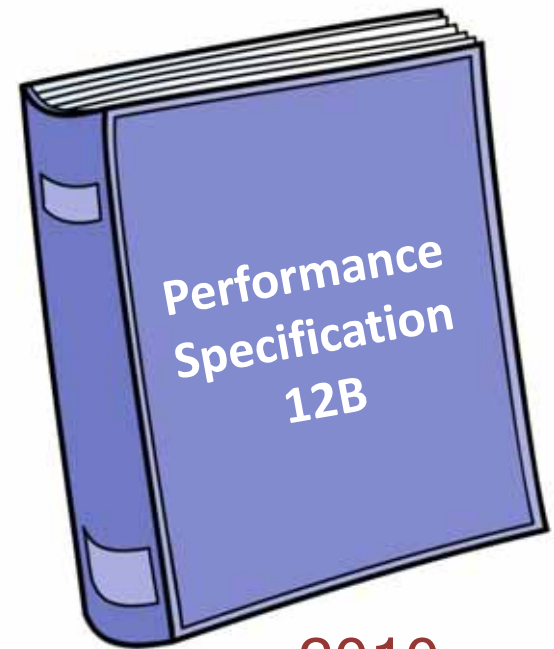

2010
PC MACT

Testing – 30B

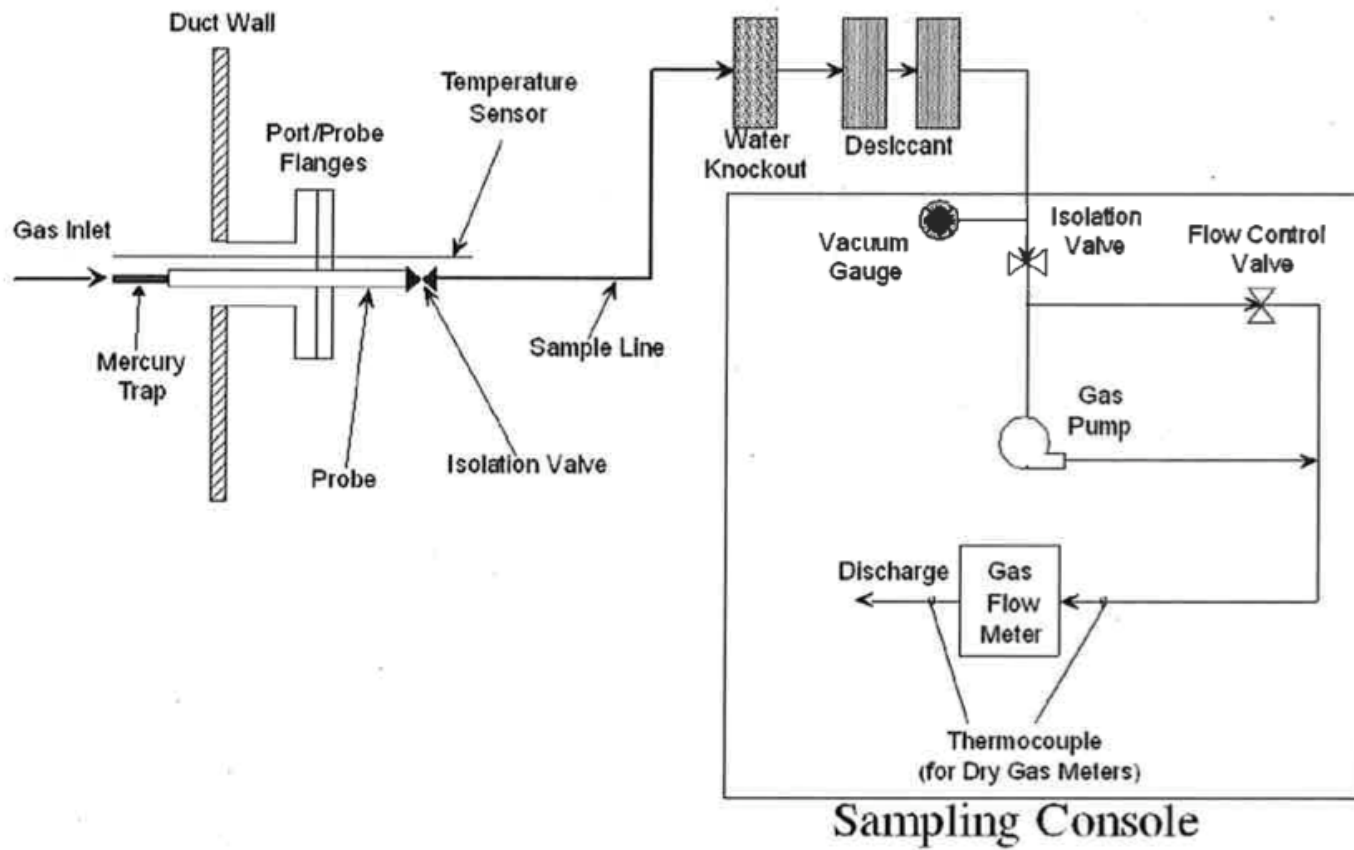

Monitoring – 12B

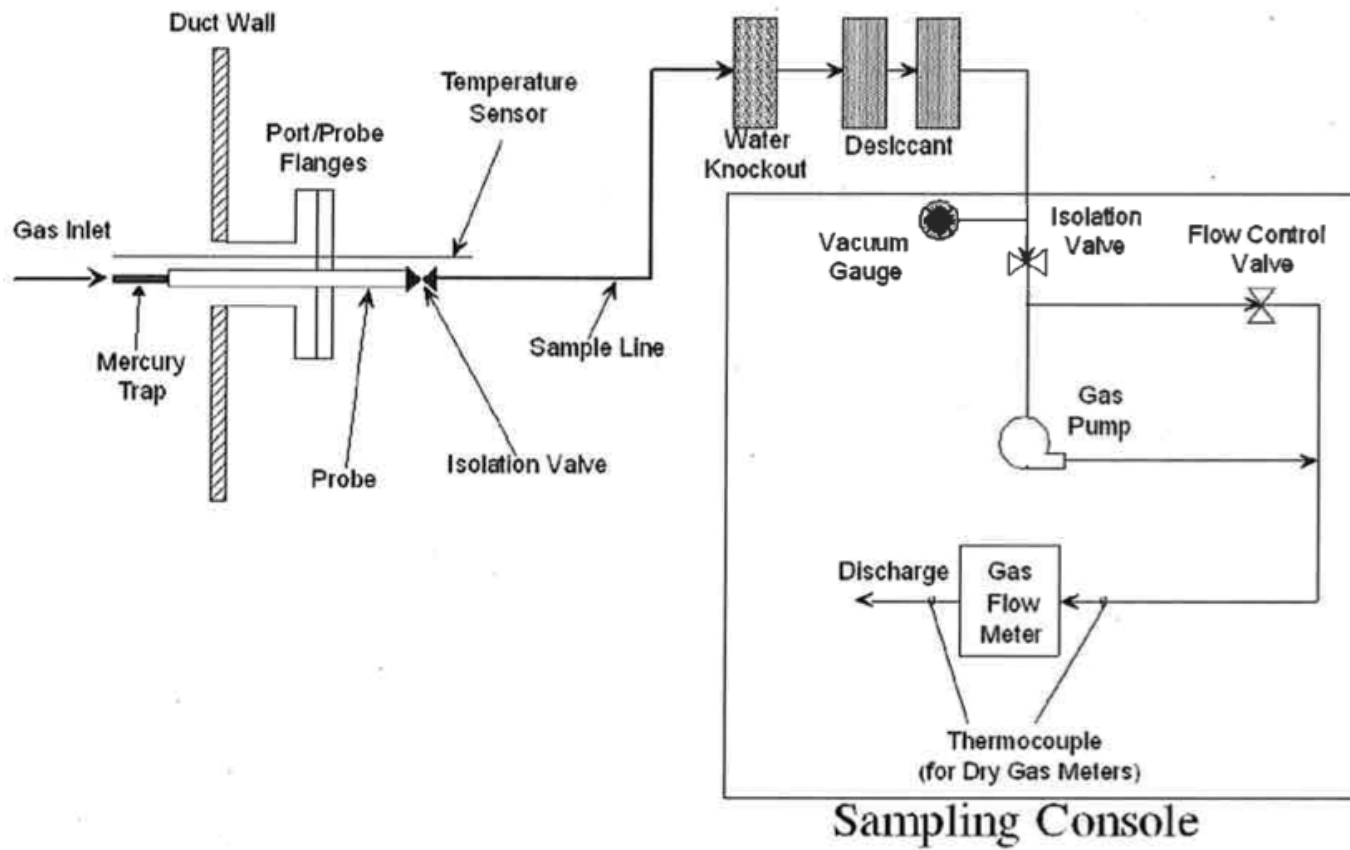

PS12B Sorbent Traps

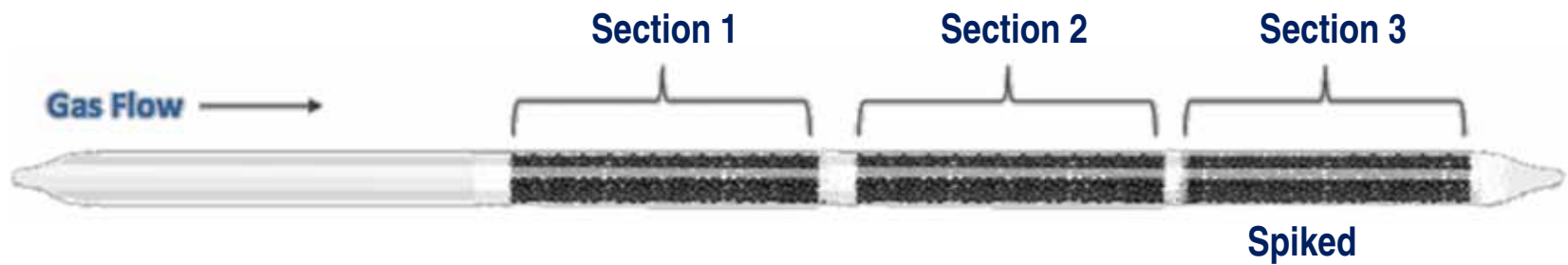
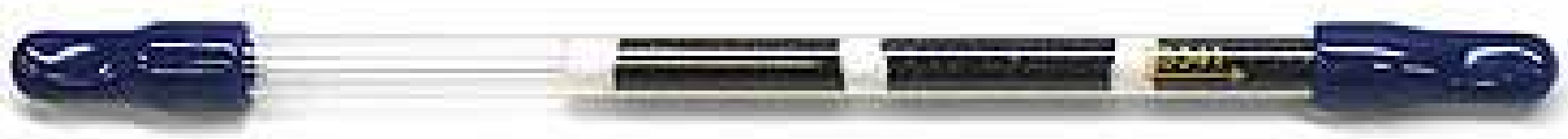

Quality Assurance

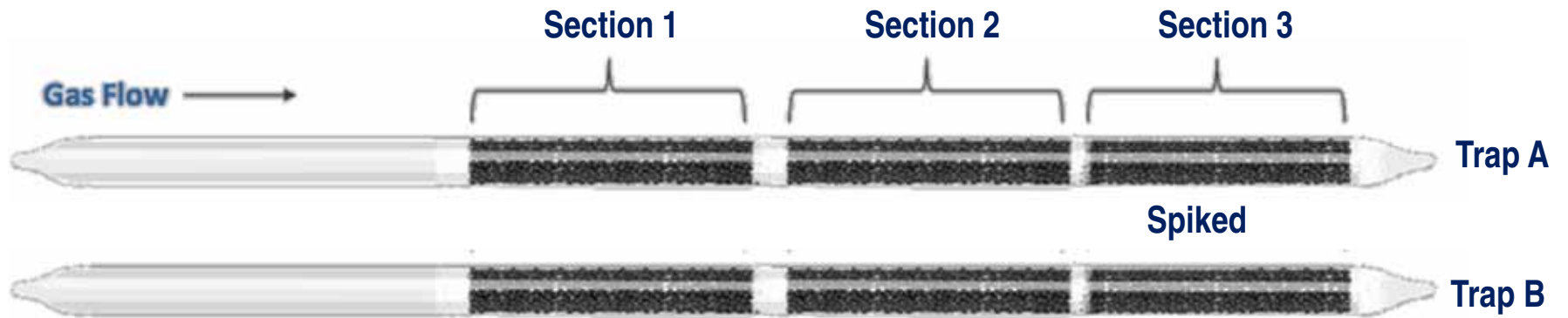

Quality Assurance

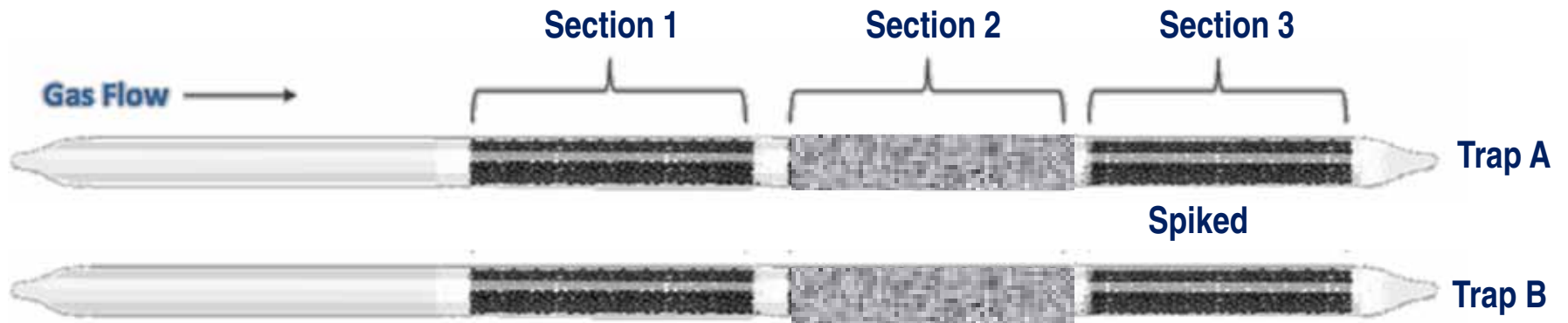

- Section 2 Breakthrough

$$\%B = \frac{M_2}{M_1} \times 100 \quad (\text{Equation 12B-5})$$

Quality Assurance

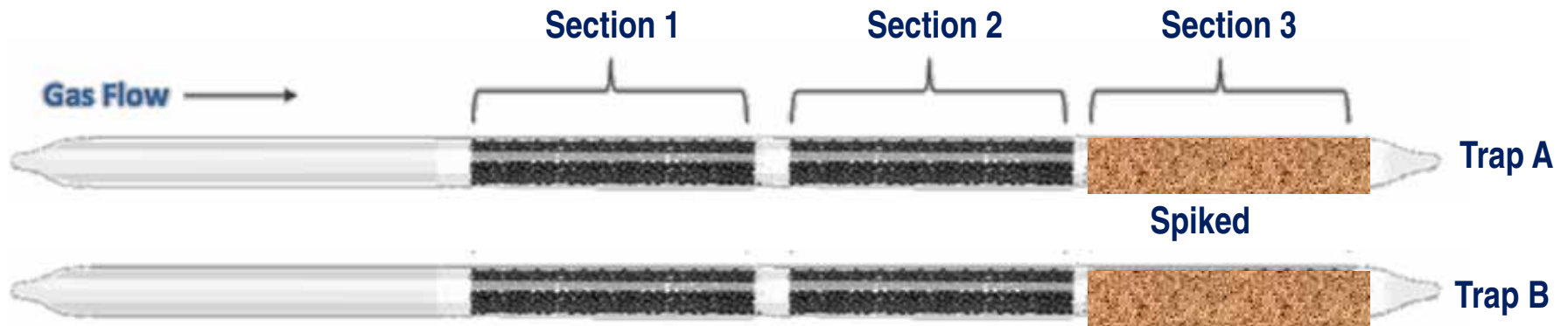

- Section 2 Breakthrough
- Section 3 Spike Recovery

$$\%R = \frac{M_3}{M_s} \times 100 \quad (\text{Equation 12B-4})$$

Quality Assurance

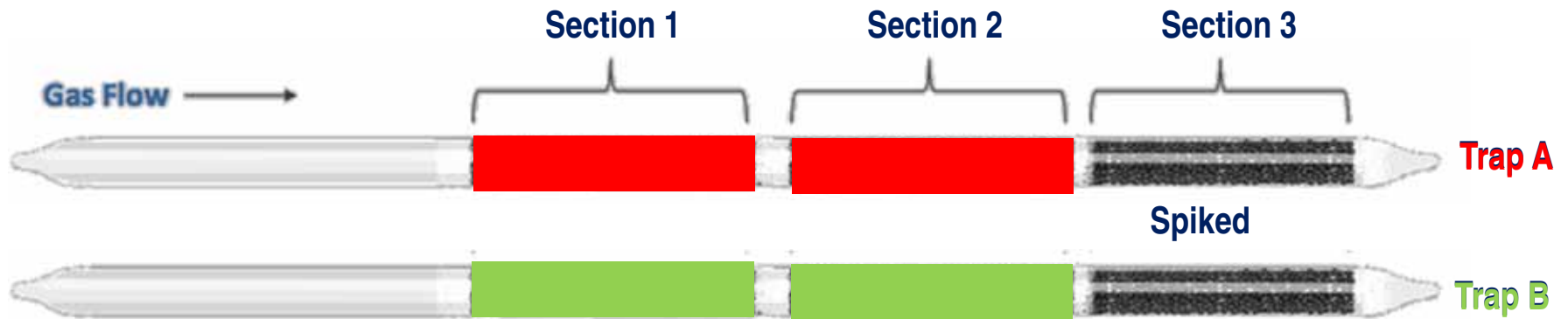

- Section 2 Breakthrough
- Section 3 Spike Recovery
- Paired sorbent trap agreement (%RD)

$$RD = \frac{|C_a - C_b|}{C_a + C_b} \times 100 \quad (\text{Equation 12B-7})$$

Sorbent Trap 103 Speciation

Modified Method 30B

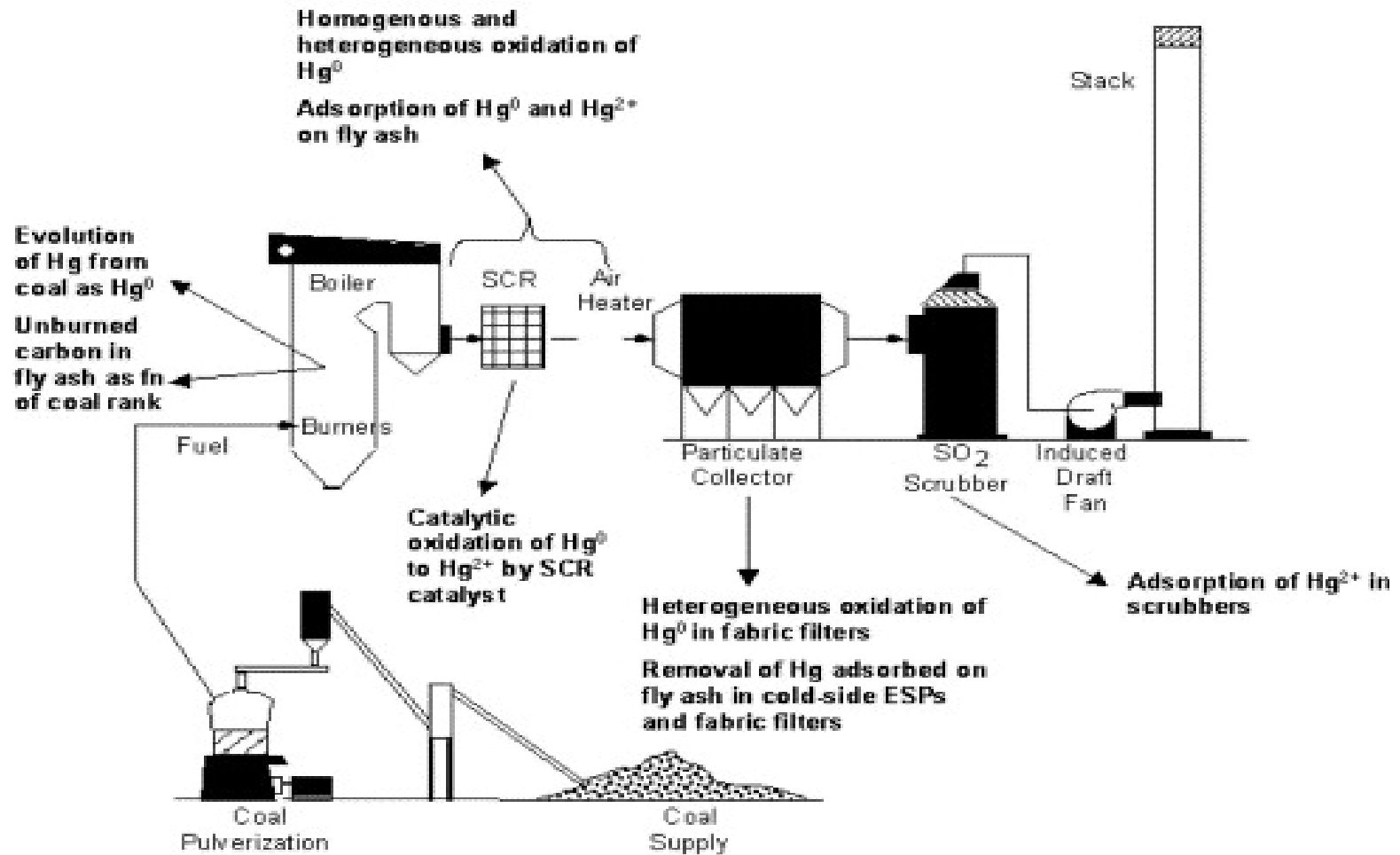

Description: FAMS (Modified US EPA Method 30B Trap – Speciation)

The FAMS method is very similar to EPA Method 30B. The FAMS method collects particulate bound mercury (PHg) on a filter and gaseous oxidized mercury Hg(II) and gaseous elemental mercury Hg(0) on solid sorbent media. While the FAMS method and Ontario Hydro method have undergone multiple side-by-side inter-comparison testing during US Department of Energy sponsored studies, there has never been a full EPA Method 301 validation of FAMS that would definitively assess its overall precision and bias.

***Modified US EPA Method 30B Trap – Speciation Version
(Flue gas Adsorbent Mercury Speciation (FAMS) Method)***



Principle Of Operation:

The FAMS sorbent trap Hg speciation method is a modified version of the US EPA Method 30B sorbent trap total Hg emissions. This modified version employs a particulate trap and a specialized sorbent trap designed to selectively capture oxidized gaseous Hg and a sorbent trap to selectively capture elemental gaseous Hg. Thus, the FAMS method relies on sequential selective capture to separate and quantify three mercury species, particulate Hg (PHg), gaseous oxidized (Hg(II)g), and gaseous elemental (Hg₀). The principle of the FAMS method has three simple steps: (1) Particulate bound Hg is captured on a pre-filter and the gas phase Hg(II) and Hg₀ pass through to the first sorbent trap section where (2) oxidized gaseous mercury is captured then finally the remaining Hg, gaseous elemental Hg is captured on the (3) EPA Method 30B trap section.

Speciation Traps

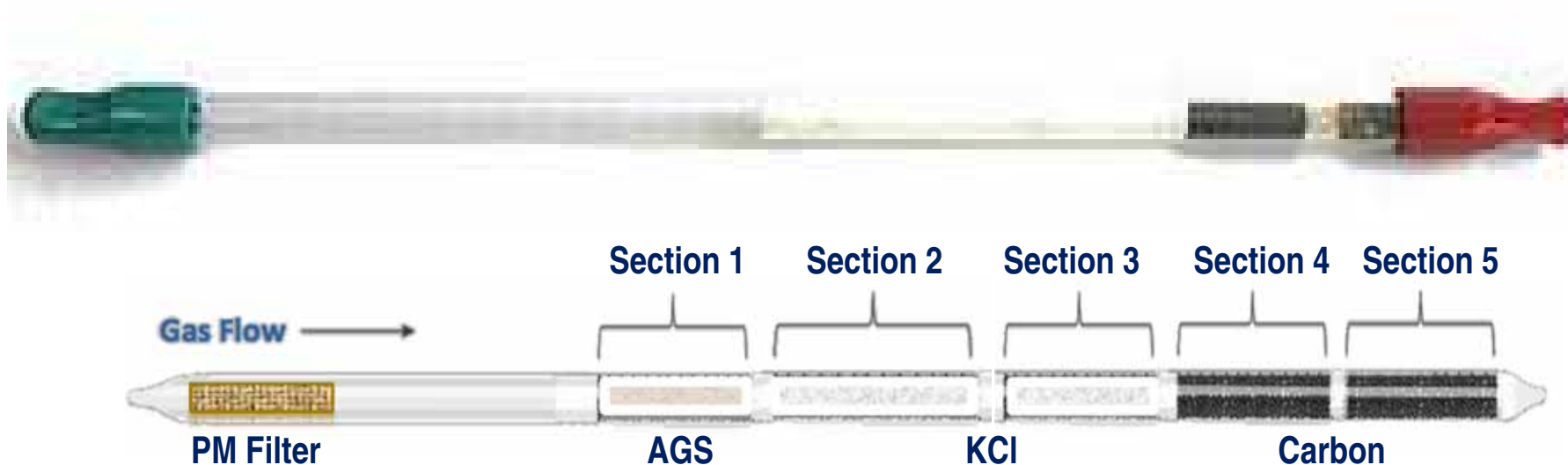

Speciation Trap Sections listed in direction from stack gas entry:

1. Acid Gas Scrubber (AGS)
2. Oxidized Mercury Analytical Bed
3. Oxidized Mercury Breakthrough Bed
4. Elemental Mercury Analytical Bed
5. Elemental Mercury Breakthrough Bed

Speciated Mercury Results

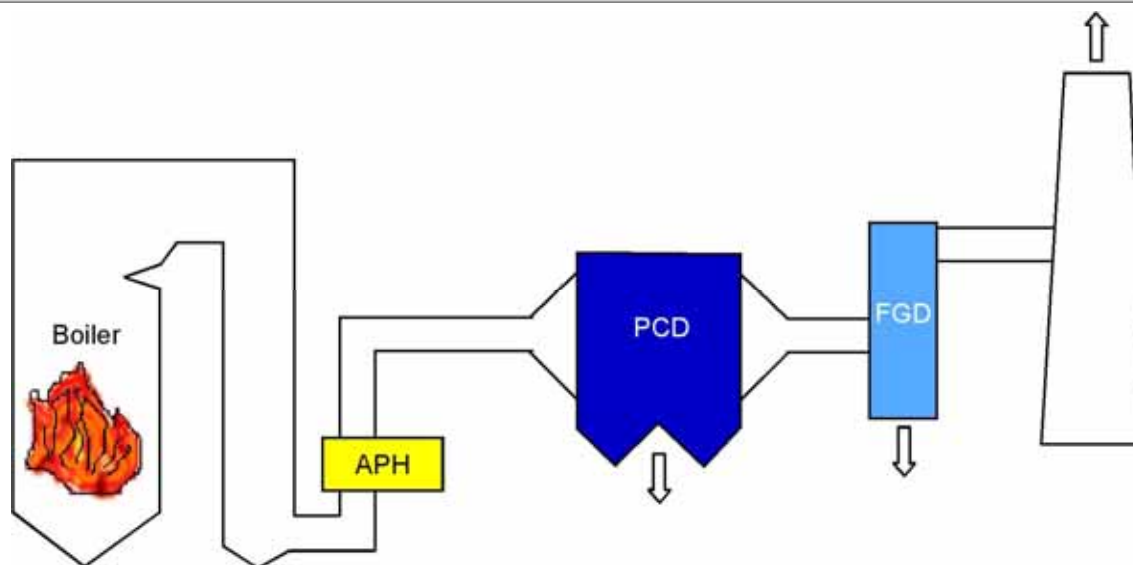
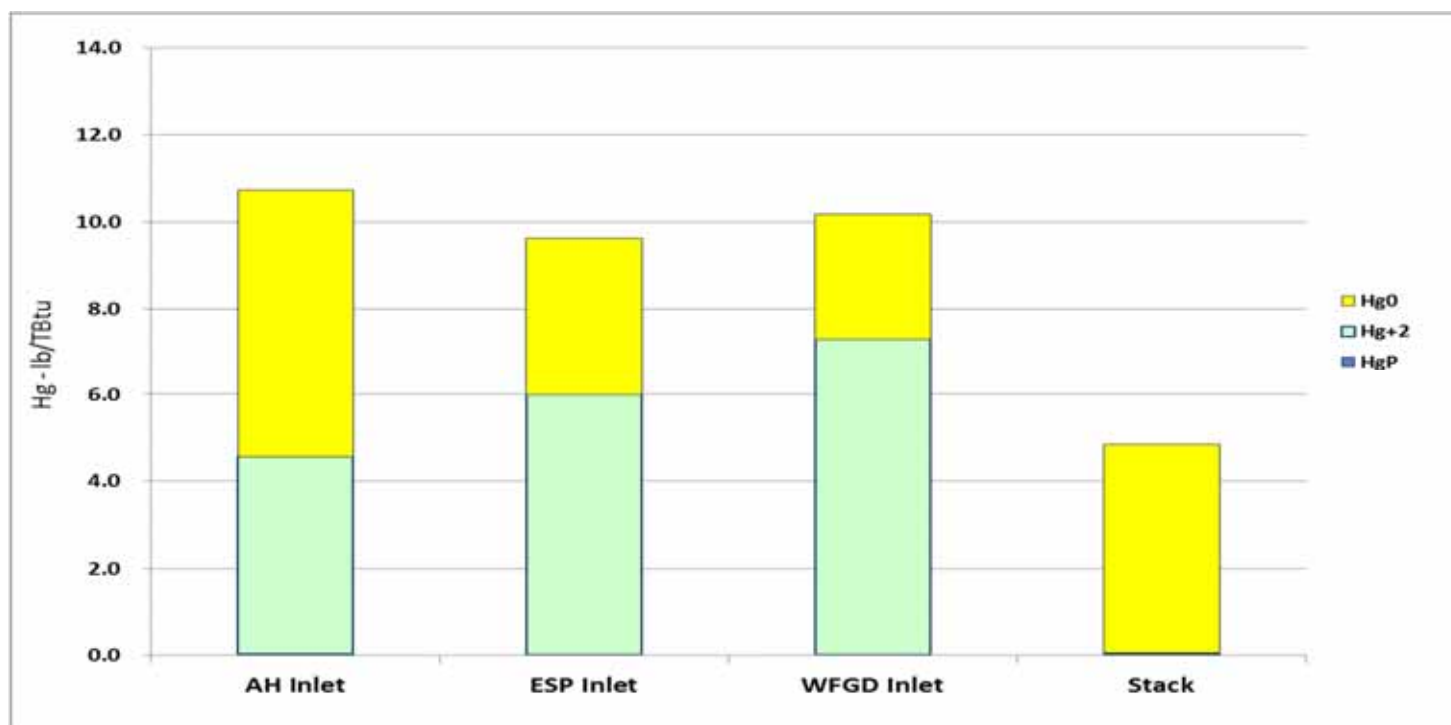

Speciated Mercury Results

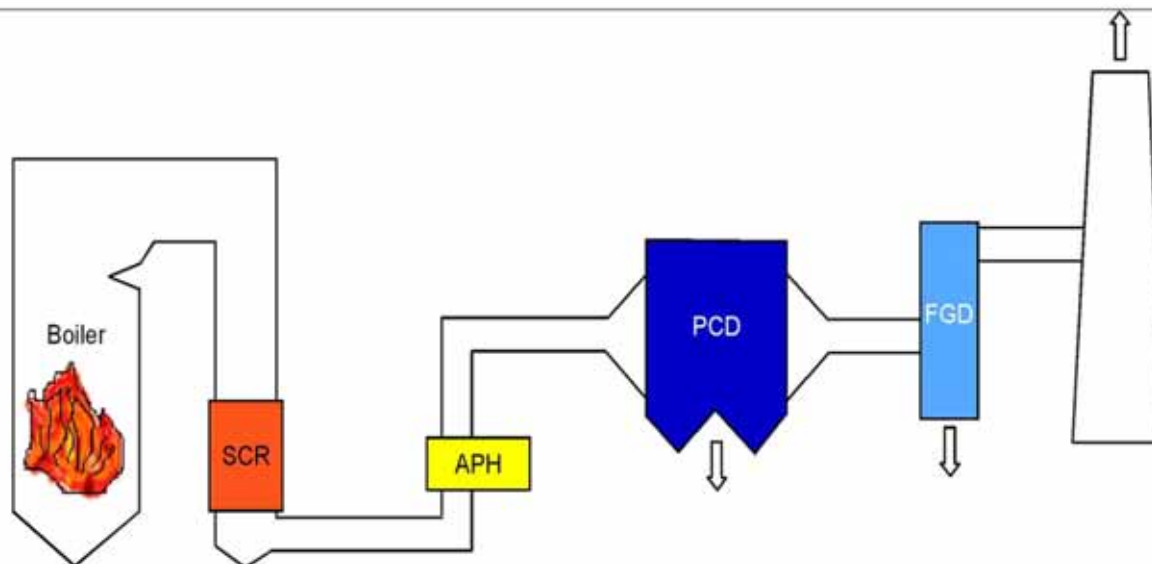
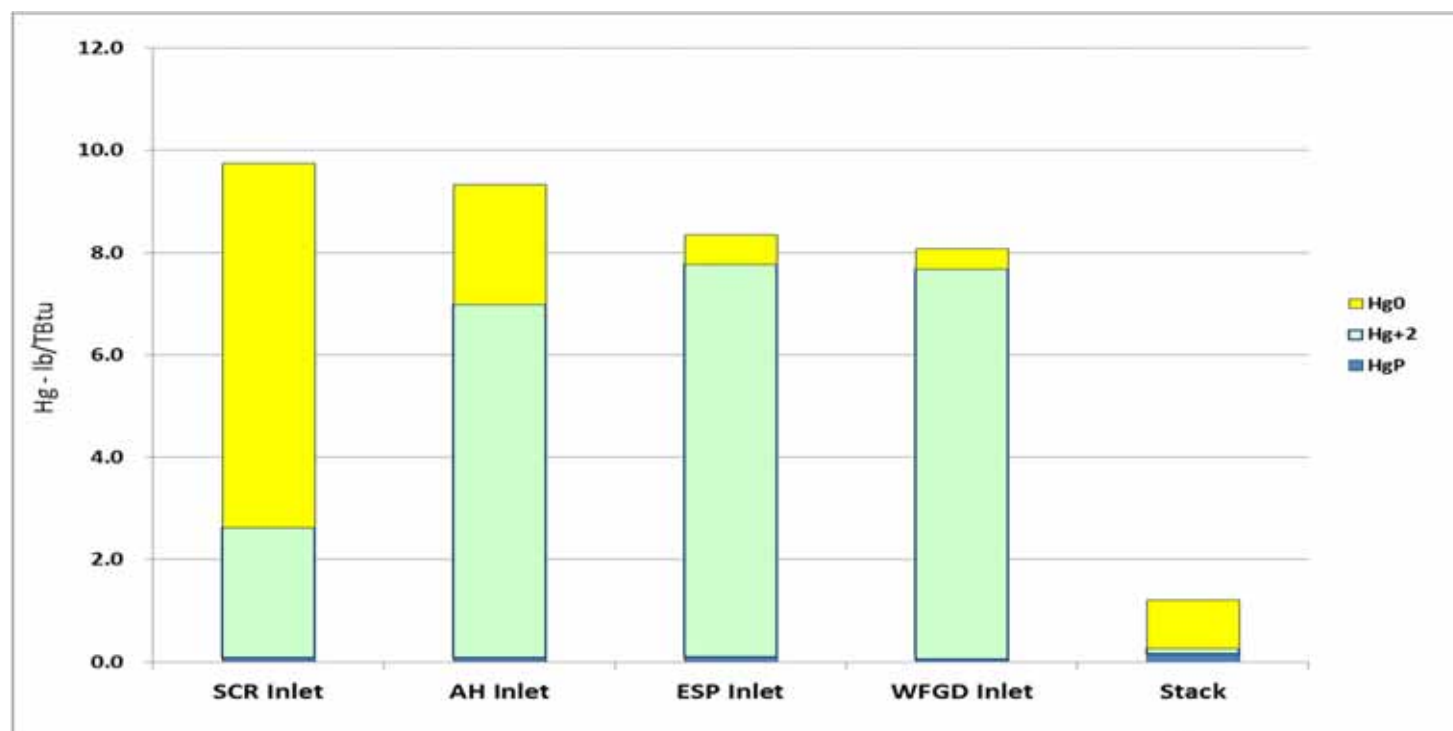

Expected Method Performance

- Trap agreement
 - 10% RD overall
 - 10-15% RD for speciation
- Breakthrough
 - 10% if $> 1 \mu\text{g/dscm}$
 - 20% if $\leq 1 \mu\text{g/dscm}$
- Spike Recovery
 - 85-115% for elemental

QA/QC Specification	Applicable Sample Fraction	Acceptance Criteria	Frequency	Consequences if Not Met
Paired sorbent trap agreement	Hg ^P	None	N/A	N/A
	Hg ⁺²	$\leq 15\%$ RD if Hg ⁺² $>1 \mu\text{g/dscm}$, $\leq 25\%$ RD or $\leq 0.25 \mu\text{g/dscm}$ absolute difference if Hg ⁺² $\leq 1 \mu\text{g/dscm}$	Every run	Invalidate run for Hg ⁺²
	Hg ⁰	$\leq 10\%$ RD if Hg ⁰ $>1 \mu\text{g/dscm}$, $\leq 20\%$ RD or $\leq 0.2 \mu\text{g/dscm}$ absolute difference if Hg ⁰ $\leq 1 \mu\text{g/dscm}$	Every run	Invalidate run for Hg ⁰
	Hg ^{vap} Hg ^T	$\leq 10\%$ RD if Hg ^l $>1 \mu\text{g/dscm}$, $\leq 20\%$ RD or $\leq 0.2 \mu\text{g/dscm}$ absolute difference if Hg ^l $\leq 1 \mu\text{g/dscm}$	Every run	Invalidate run for Hg ^T or Hg ^{vap}
Oxidized Breakthrough (KCl sections)	Hg ⁺²	Section 3 KCl contains $\leq 10\%$ of the Section 1 and 2 masses if Hg ⁺² $>1 \mu\text{g/dscm}$, Section 3 contains $\leq 20\%$ of the Section 1 and 2 masses if Hg ⁺² $\leq 1 \mu\text{g/dscm}$	Every trap	Invalidate trap data for Hg ⁺² and Hg ⁰
Elemental Breakthrough (carbon sections)	Hg ⁰	Section 2 carbon contains $\leq 10\%$ of the Section 1 mass if Hg ⁰ $>1 \mu\text{g/dscm}$, Section 2 contains $\leq 20\%$ of the Section 1 mass if Hg ⁰ $\leq 1 \mu\text{g/dscm}$,	Every trap	Invalidate trap for Hg ⁰ , Hg ^T , and Hg ^{vap}
Field Recovery Test	Hg ⁰	Average recovery between 85% and 115% for Hg ⁰	Minimum three spikes per program	Flag data

Method Pitfalls

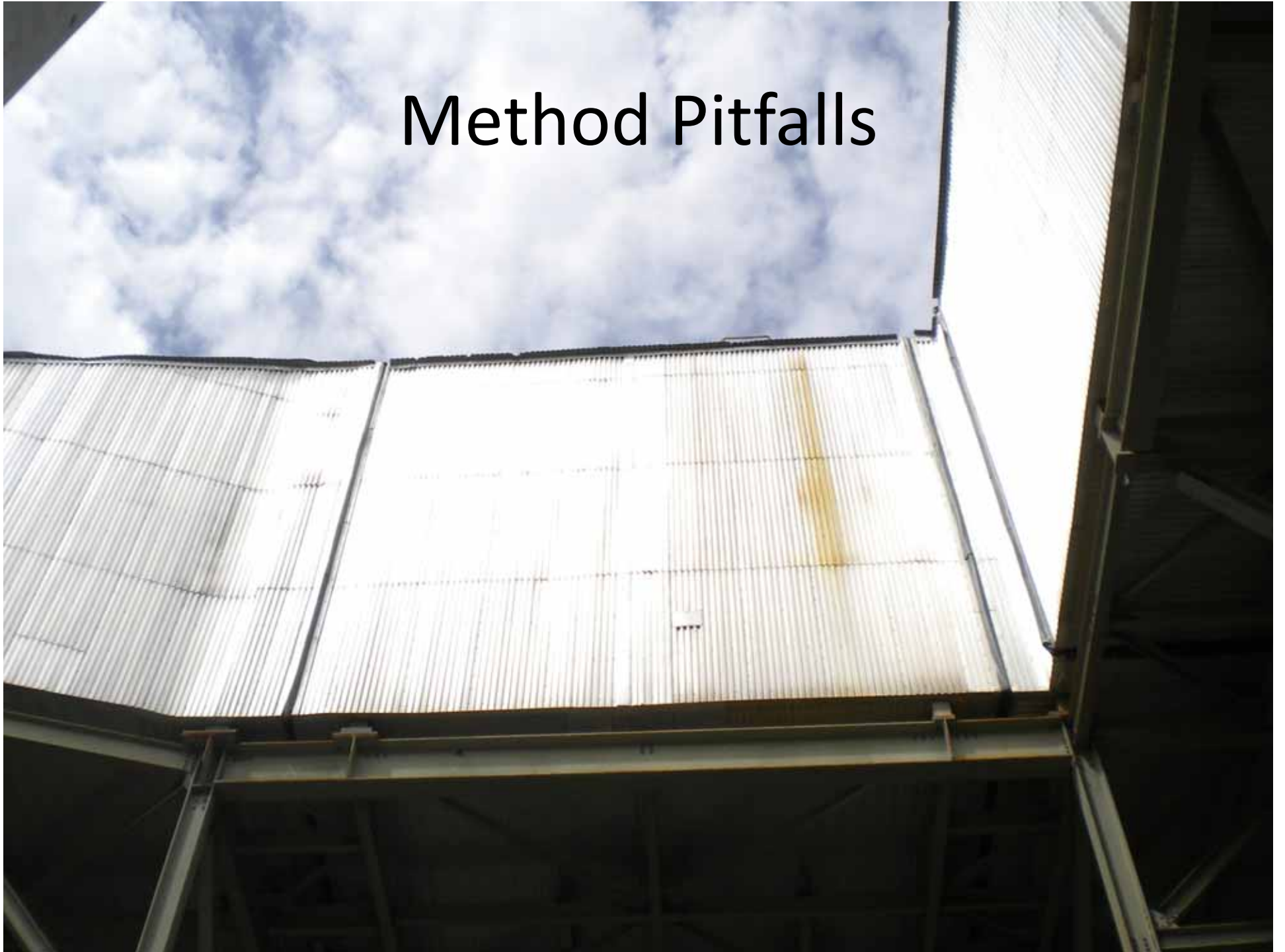

Method Pitfalls

High Temperature

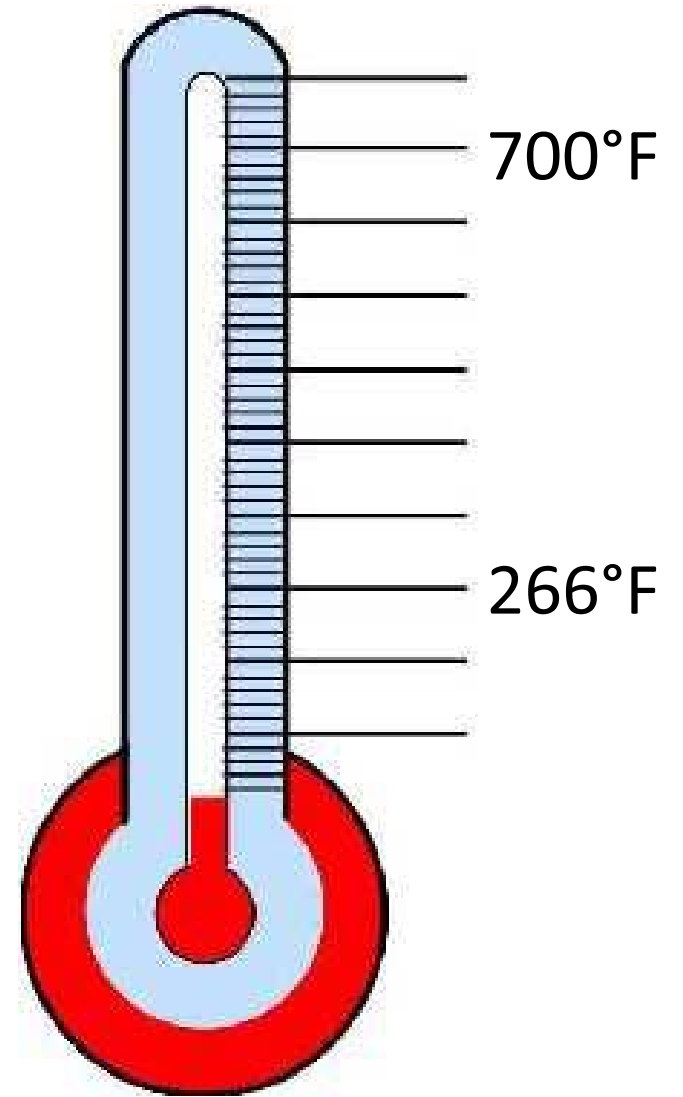

Method Pitfalls

High
Dust
Load



Method Pitfalls

Hg Conversion

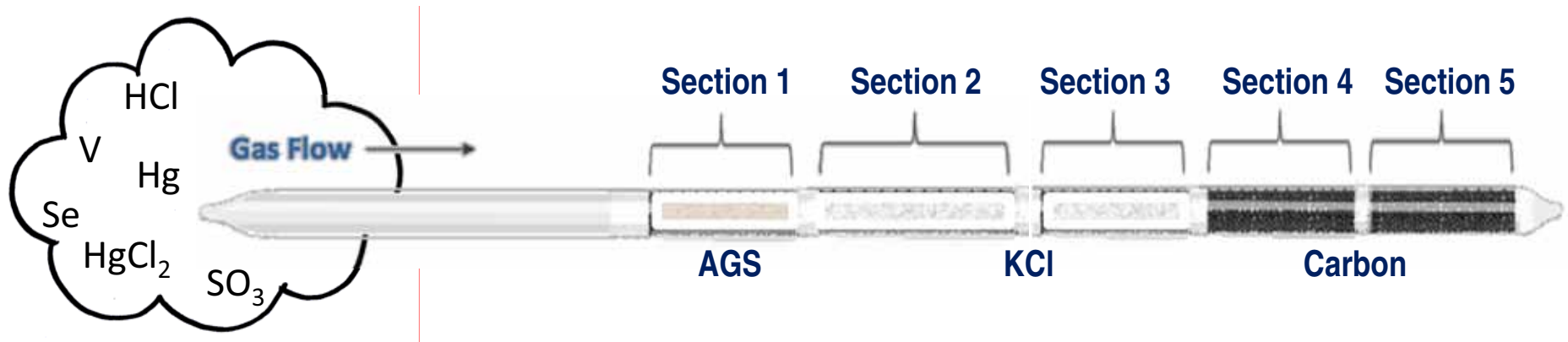

Solutions

Solutions

- Air-cooled probes



Solutions

- Air-cooled probes
- Short trap extensions w/PM filter



Solutions

- Air-cooled probes
- Short trap extensions w/PM filter
- Short sampling durations

